

TIMEX

model

102

SERVICE MANUAL
MODEL 102

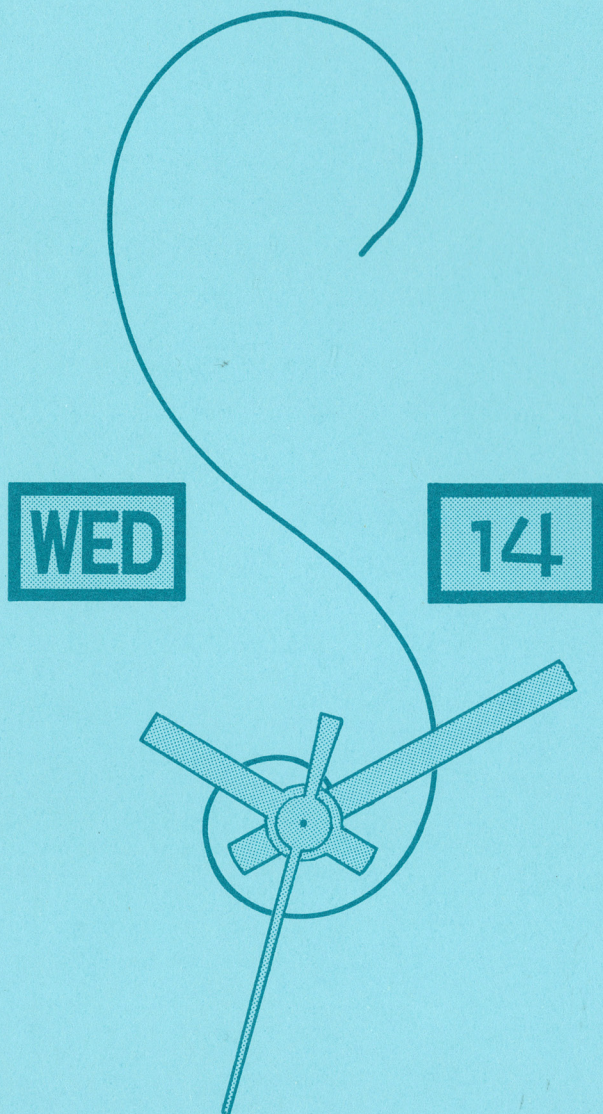

9½ lig.
21.44 mm
844 in.

The TIMEX® Model 102 Movement

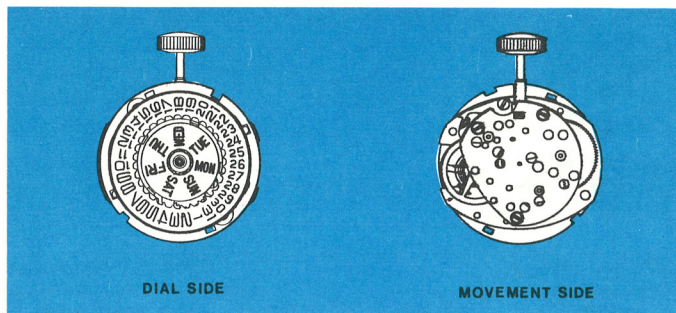

SHOWN ACTUAL SIZE

THE TIMEX MODEL 102 IS A 9½ LIGNE DAY AND DATE MOVEMENT WITH "V-CONIC" BALANCE BEARINGS.

THE MODEL 102 MOVEMENT IS THE SAME AS THE MODEL 100 WITH THE ADDITION OF THE DAY AND DATE MECHANISM.

THE DATE MAY BE ADVANCED QUICKLY.

THE TIMEX CODE NUMBER APPEARS ON THE EDGE OF THE DIAL.

THE CODE NUMBER SHOWS THE CATALOG NUMBER, MOVEMENT NUMBER AND YEAR OF MANUFACTURE FOR THE WATCH (SEE PAGE 1.1 OF THE TIMEX SERVICE MANUAL FOR EXPLANATION).

The **TIMEX**® Model 102 Movement (exploded view)

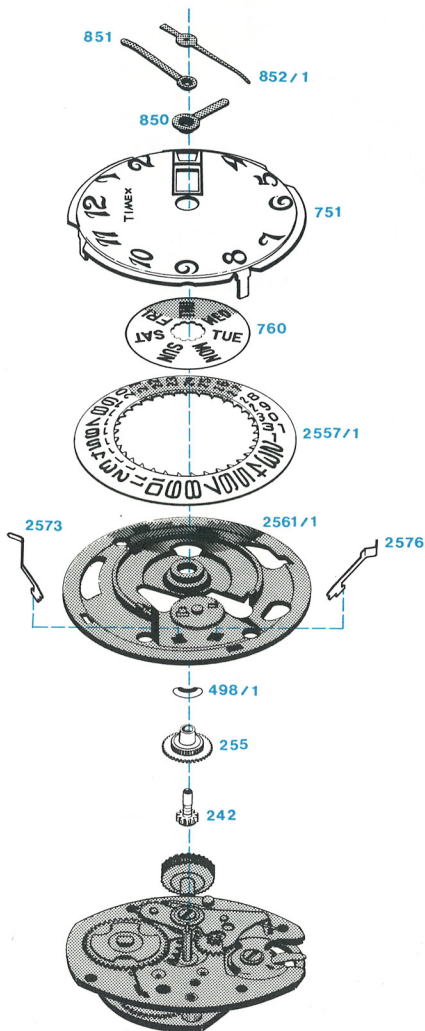

- 242 CANNON PINION ASS'Y.
- 255 HOUR WHEEL ASS'Y.
- 498/1 HOUR WHEEL WASHER
- 751 DIAL
- 760 DAY DISC
- 850 HOUR HAND
- 851 MINUTE HAND
- 852/1 SWEEP SECOND HAND
- 2557/1 DATE RING
- 2561/1 DAY / DATE FRAME ASS'Y.
- 2573 DAY DETENT SPRING
- 2576 DATE DETENT SPRING

Disassembly of Model 102 Movement

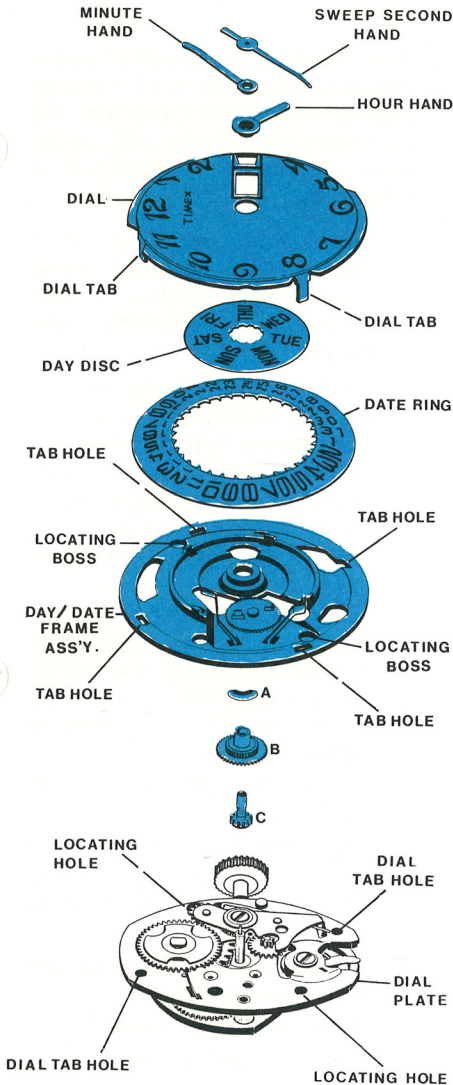

To disassemble the Model 102 for cleaning, it is necessary to:

- A. Remove all Hands.
- B. Straighten the dial tabs so they will pass through the holes. Turn the assembly over and lift off the Dial, the Day Disc, the Date Ring and the Day-Date Frame Assembly.
- C. Remove the Hour Wheel Washer (A), Hour Wheel Assembly (B) and Cannon Pinion Assembly (C) from the Movement.
- D. After the above parts have been removed, the basic movement can be disassembled, cleaned, lubricated and reassembled as outlined for the Model 100 Movement starting on Page 100.3.
- E. The Hour Wheel Washer, Hour Wheel Assembly, Cannon Pinion Assembly and Day-Date Frame Assembly may be cleaned using standard watch cleaning solutions.

CAUTION: Extreme care must be exercised in cleaning Dials, Hands, Day Discs and Date Rings. Solvent type cleaners will often damage the finish on these parts.

Reassembly of the Model 102 Movement

After the basic movement has been cleaned, lubricated and reassembled as outlined for the Model 100 movement, the Model 102 movement reassembly is completed as follows:

- A. Make certain the Day Detent Spring and Date Detent Spring are correctly located in Day-Date Frame Assembly (see Figure 1).
- B. Lubricate the bearing face of the Day Detent Spring and the Date Detent Spring with a thin film (AVOID EXCESS LUBRICATION) of non-spreading watch oil (Moebius Synt-a-Lube oil is used in the factory) as shown in Figure 1.

Lubricate the vertical wall of the Day-Date Frame with a thin film of spreading type watch oil (Woods AAAA Oil is used in the factory) as shown in Figure 1.

DO NOT LUBRICATE DATE WHEEL AREA.

Apply non-spreading watch oil to the end of the Cannon Pinion Assembly as shown in Figure 2.

- C. Replace parts on the movement in the following order:
 - Cannon Pinion Assembly
 - Hour Wheel Assembly
 - Hour Wheel Washer
 - Day-Date Frame Assembly—orient as shown on Page 102.3 and seat bosses in holes.

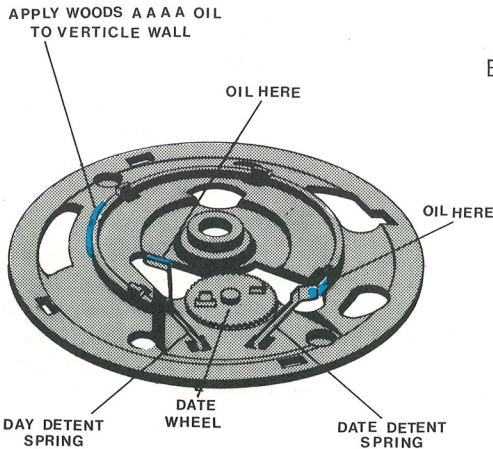

FIGURE 1

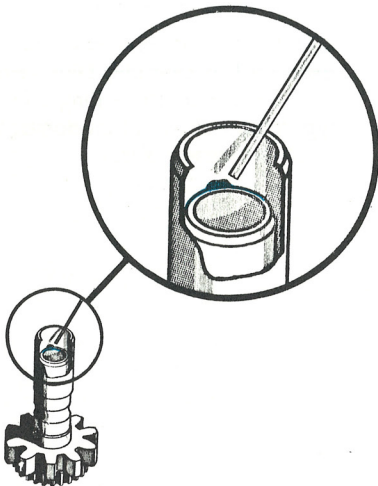

FIGURE 2

Reassembly of the Model 102 Movement

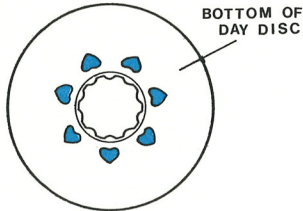

FIGURE 3

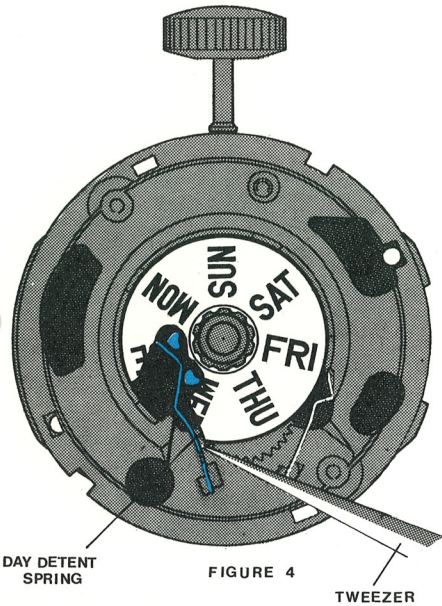

FIGURE 4

DAY DETENT SPRING

TWEezer

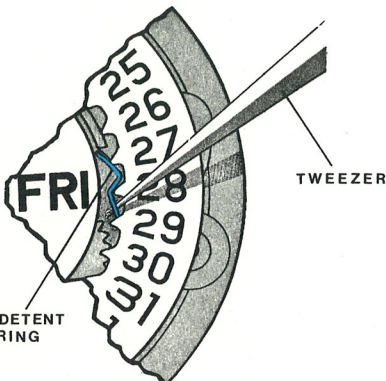

FIGURE 5

DATE DETENT SPRING

TWEezer

Day Disc—Note protrusions on back of disc (see Figure 3)—place disc on Day-Date Frame Assembly with any day (i.e. Sun.) in line with Crown and Stem. With fine tweezers, deflect Day Detent Spring outward until Day Disc drops into place (see Figure 4).

Date Ring—position Date Ring centrally on Day-Date Frame Assembly. With fine tweezers, deflect Date Detent Spring inward until the Date Ring drops into place (see Figure 5).

Dial—orient Dial as shown on Page 102.3 with windows toward Crown and Stem and insert tabs through Day-Date Frame Assembly into Dial Plate of movement.

Hold Dial in place on movement, turn assembly over and bend tabs firmly against back of Dial Plate.

D. Pull Crown and Stem out and rotate clockwise until the date changes (with a snap). Stop turning the crown immediately and assemble Hands at the 12 o'clock position.

Check assembly to be sure date changes at 12 o'clock and day change is completed by 3:30.