

# TIMEX® Model 107

SERVICE MANUAL  
MODEL 107

13 lig.  
29.4 mm  
1.160 in.

# The **TIMEX®** Model 107 Movement

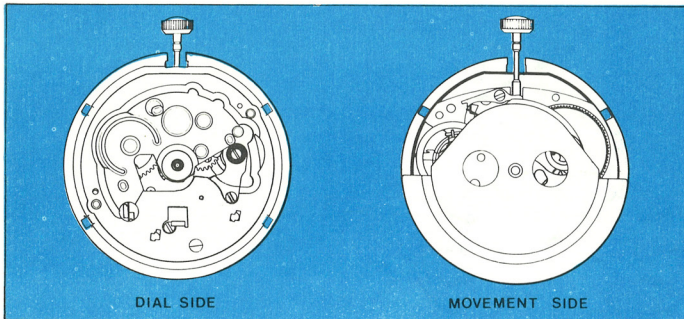

SHOWN ACTUAL SIZE

The Model 107 movement is a 13 ligne self-wind movement featuring the Timex "V-Conic®" bearing system and two plate design. The Model 107 contains a planetary gear self-winding system. The routine movement of the wrist of a normally active person is sufficient to keep the watch running without manual winding.

The basic movement is similar to the Timex Model 104.

The Timex code number appears on the edge of the dial. The code number shows the catalog number, movement number, and year of manufacture for the watch (see page 1.1 of the Timex Service Manual for explanation).

# The TIMEX® Model 107 Movement (exploded view)

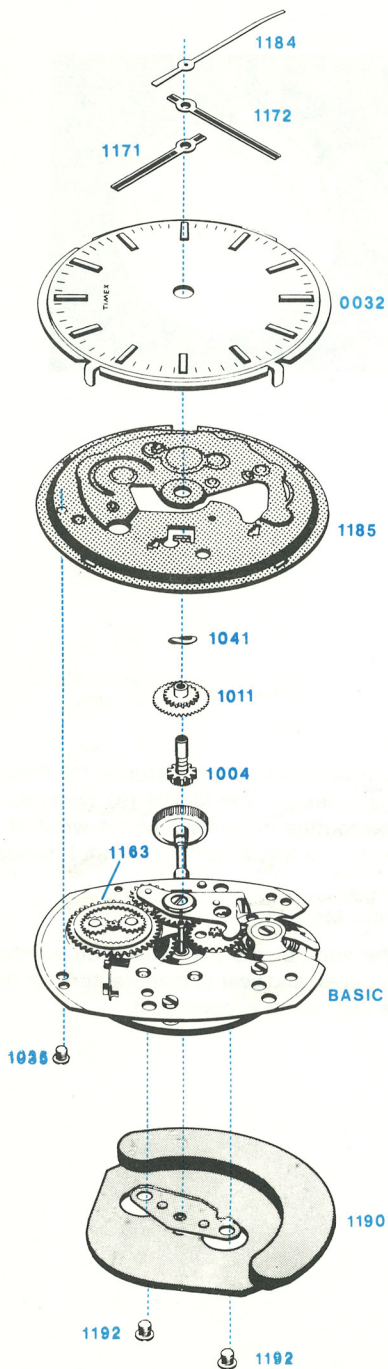

- 0032 DIAL
- 1004 CANNON PINION ASS'Y
- 1011 HOUR WHEEL ASS'Y
- 1036 SCREW
- 1041 HOUR WHEEL WASHER
- 1163 RATCHET WHEEL
- 1171 HOUR HAND
- 1172 MINUTE HAND
- 1184 SWEEP SECOND HAND
- 1185 DIAL REST
- 1190 ROTOR PLATE ASS'Y
- 1192 ROTOR PLATE SCREW

BASIC MOVEMENT

# Disassembly of the Model 107 Movement

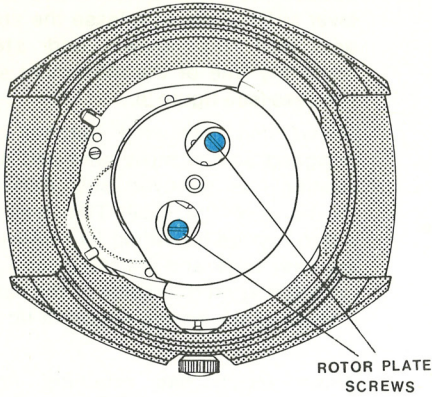

FIGURE 1

The Model 107 movement is disassembled as follows: Remove the caseback. Loosen and remove two rotor plate screws (see figure 1). Lift the Rotor Assembly slightly to free the dowels. Since the rocker arm fits between the Rotor Frame and the Rotor Assembly, position the rotor weight as shown in figure 2 and slide the assembly along the movement plate, (toward the balance wheel) until it is free of the rocker arm and then lift the assembly out of the case.

**CAUTION:** Any attempt to lift the weight before it is free of the rocker arm will result in damage to the movement.

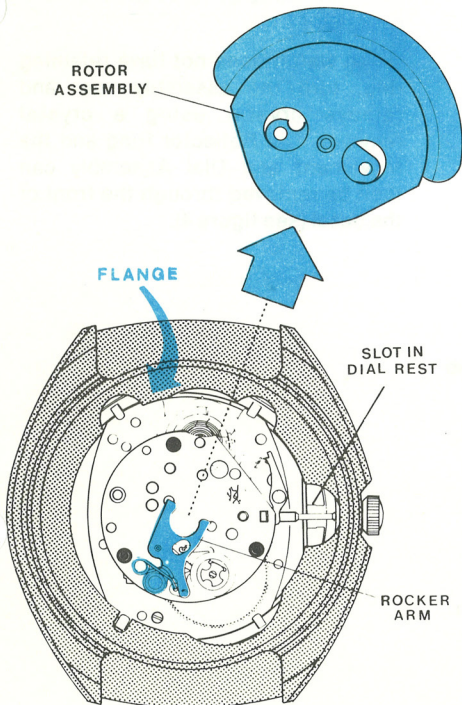

FIGURE 2

# Disassembly of the Model 107 Movement

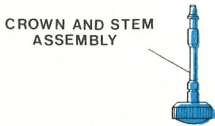
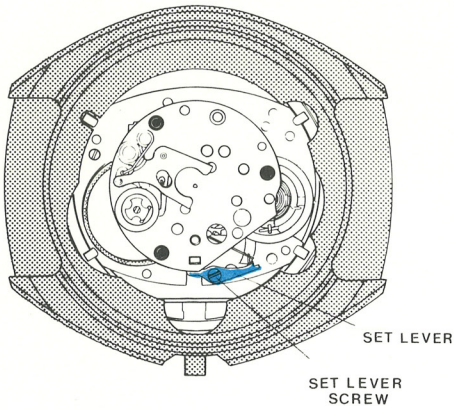

FIGURE 3

Loosen the set lever screw and raise lever sufficiently to release the stem and pull the crown and stem assembly free of the movement and the case (see figure 3).

Some Timex self-wind watches are designed so the movement and dial assembly is removed only through the back of the case. This type of watch can be identified by removing the case back and checking for a retaining ring on the inside of the bezel instead of the flange shown in figure 1.

When watch has retaining ring, do not try to remove the crystal. Carefully free retaining ring from case groove and remove. Movement and Dial Assembly may then be removed through the back of the case.

When watch does not have retaining ring, turn the assembly over and remove crystal using a crystal remover. The Reflector Ring and the Movement and Dial Assembly can then be removed through the front of the bezel (see figure 4).

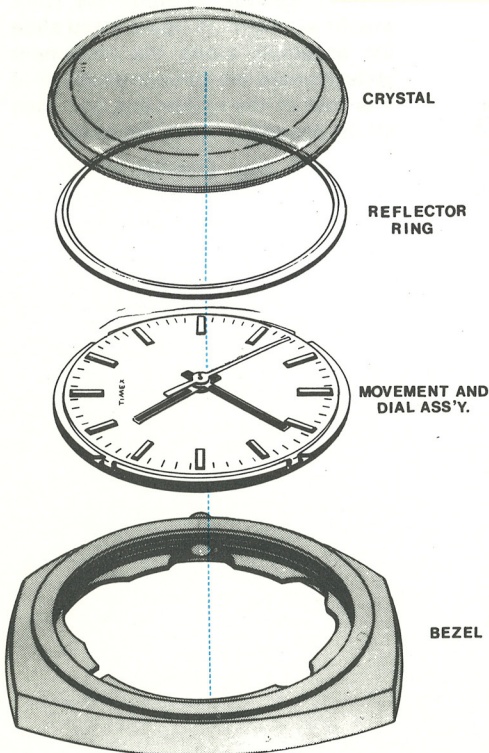

# Disassembly of Movement Cont'd.

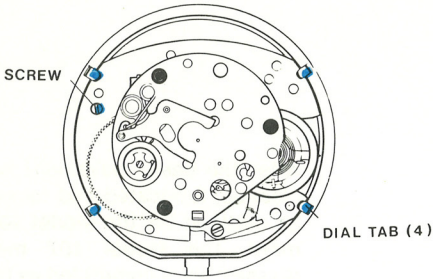

FIGURE 5

Remove all hands.

Turn the assembly over and bend the four dial tabs sufficiently to free the dial from the dial rest and movement, (see figure 5). Hold the dial in place and turn the assembly over so the dial is up. Lift the dial off the assembly, (see figure 6).

With the above parts removed, the basic movement may be replaced with a Timex reconditioned movement. The parts removed above are assembled to the reconditioned movement as described starting on page 107.9.

Replace the crown and stem assembly in the movement and tighten the set lever screw to assure engagement. Release the mainspring power slowly by holding the crown in the fingers of one hand, while the click is held out of engagement (through the hole in the dial rest) with the ratchet wheel. After the mainspring power is released, turn the assembly over (dial rest down) and remove the screw securing the dial rest. Turn the assembly over and lift off the dial rest and the ratchet wheel.

Remove the Hour Wheel Washer (A), Hour Wheel Assembly (B), and Cannon Pinion Assembly (C) from the movement.

With the above parts removed, the movement of the Model 107 may be cleaned and relubricated as outlined for the Model 104 movement. Other metal parts may be cleaned in the same manner as the movement.

### CAUTION

Extreme care must be exercised in cleaning dials and hands. Solvent type cleaners will often damage the finish on these parts.

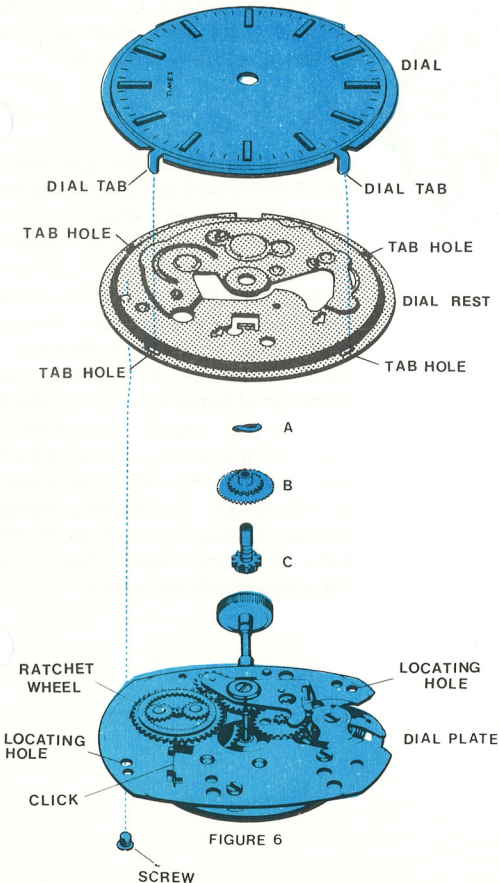

FIGURE 6

# Reassembly of the Model 107 Movement

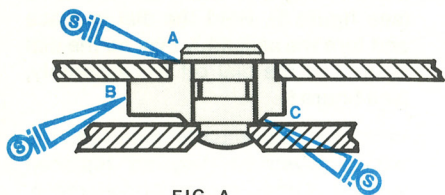

FIG. A

After the basic movement has been cleaned, lubricated and reassembled as outlined for the Model 104 movement, the Model 107 movement reassembly is completed as follows:

Apply grease (Moebius special lubricant is used in the factory) to 3 points on the Rotor Frame Assembly as noted on figure A. Apply grease to rotor cam (surface A). Force grease beneath rotor staff head (at B) and underside of rotor cam (at C).



FIG. B

Assemble ratchet wheel and dial rest (see P 107.5) and secure with screws. Rotate crown until mainspring and slip tail are positioned as noted on figure B. Apply drop of spreading type oil (Woods AAAA oil is used in the factory) in space between mainspring and inside diameter of barrel, or between slip tail and inside diameter of barrel through opening in the dial rest. Rotate crown so that mainspring and slip tail make 2 complete revolutions within the barrel to distribute the oil properly. Release mainspring power slowly as noted on page 107.5 and then remove screw, dial rest and ratchet wheel.

 MOEBIUS SPECIAL LUBRICANT  
 WOODS AAAA OIL

# Reassembly of the Model 107 Movement

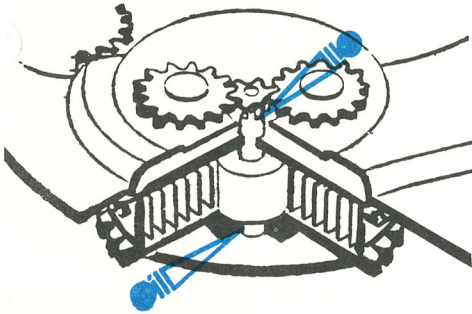

FIG. C

Place spreading type watch oil on main arbor flat on one side permitting oil to contact root of planet wind pinion teeth. From this point, drag oiler over the top of planet wind pinion down to main arbor flat on opposite side; apply spreading type oil to bearing surface between barrel hub and movement plate (see figure C).

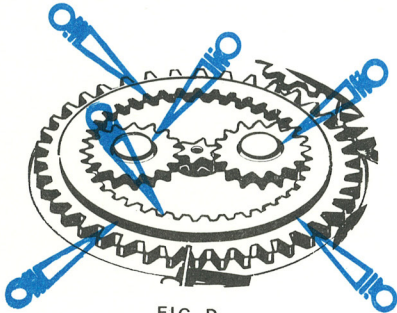

FIG. D

Apply non-spreading type oil (Moebius Synt-A-Lube is used in the factory) to 6 points on the Ratchet Wheel and Planet Pinion Assembly as noted on figure D.

Apply non-spreading type oil to 4 points on the Rocker Arm Assembly and Winding Ratchet Wheel as noted on figure E.

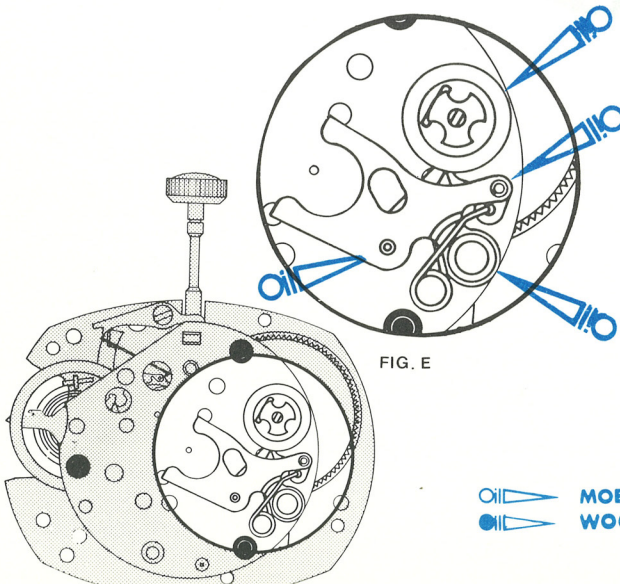
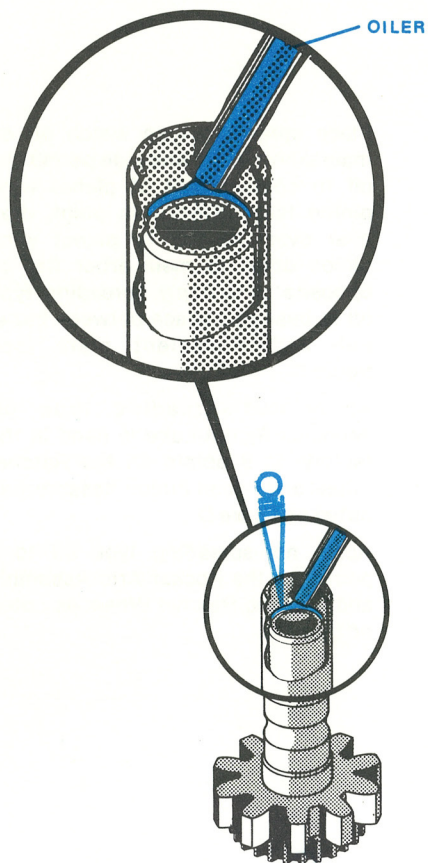

FIG. E

 MOEBIUS SYNT-A-LUBE  
 WOODS AAAA OIL



# Reassembly of the Model 107 Movement



Apply non-spreading watch oil to the end of the Cannon Pinion as shown in the lower illustration at the left.

# Reassembly of the Model 107 Movement

- A. Replace parts on the movement in the following order:

Cannon pinion assembly  
Hour Wheel Assembly  
Hour Wheel Washer  
Ratchet Wheel—be sure the Ratchet Wheel is seated and properly engaged with the click and the Rocking Bar Assembly.

Dial Rest—Orient Dial Rest with the slot at the stem (see figure 6 on page 107.5) and seat bosses in holes.

Hold the assembly together and turn over so the dial rest is down and insert and tighten screw.

- B. Dial—Orient Dial as shown on page 107.3 and insert dial tabs through the holes in the dial rest. Hold dial in position on the movement, turn the assembly over and bend the tabs firmly over the edge of the dial plate.
- C. Assemble hands at the 12 o'clock position.
- D. Position the Dial and Movement Assembly in the bezel; insert the reflector ring and replace the crystal. Insert the Crown and Stem Assembly through the bezel and into the movement and tighten the set lever screw.
- E. Reassemble the Rotor Assembly by sliding it into the movement under the rocker arm as shown in figure 2. (Notch in the rotor frame points towards the balance assembly.) Secure the rotor to the movement with two screws as shown in figure 1. (It is sometimes easier to assemble the Rotor Assembly to the movement first when Movement and Dial Assembly is to be assembled through the back of the case and secured with a retaining ring.)
- F. Position the caseback so the crown is to the left when the words are upright. Recheck watch for proper function.