

# TECHNICAL GUIDE

## AND PARTS LIST

CAL. V10 SERIES

# ANALOGUE QUARTZ

## CONTENTS

I. FOREWORD .....	1
II. SPECIFICATIONS .....	2
III. LIST OF SCREWS USED.....	2
IV. STEP MOTOR LOAD-COMPENSATIVE DRIVING PULSE SYSTEM .....	3
V. STRUCTURE OF CIRCUIT BLOCK.....	3
VI. DISASSEMBLING, REASSEMBLING AND LUBRICATING .....	4
(1.) Disassembly and reassembly of casing parts .....	4 - 5
(2.) Calendar mechanism.....	6
(3.) Circuit block · Drive coil · Train wheel, Selector mechanism .....	7
VII. CLEANING.....	8
VIII. CHECKING AND ADJUSTMENT .....	9
(1.) Guide table for checking and adjustment.....	9
(2.) Procedure for checking and adjustment.....	10
A. Quick start function.....	10
B. Fully charged capacitor .....	10
C. Circuit block conductivity .....	10
D. Capacitor .....	10
E. Movement.....	11
F. Reset condition .....	11
G. Coil block .....	12
H. Output signal.....	12
I. Accuracy .....	12
Current consumption .....	12
IX. PARTS LIST.....	13 - 14

## I. FOREWORD

The Cal. V10 series is the world's first analogue watch powered by a combination of a newly developed capacitor and an amorphous solar battery.

### «Features»

#### 1. No need for battery replacement:

- As a means of storing and releasing electrical energy, a capacitor is used instead of the conventional silver oxide battery.

Even after being left unused for a long period, the watch recharges when held up to light.

#### 2. Quick start function

Even when the capacitor is completely discharged, the watch recharges and will start within a few seconds after exposed to a strong light (More than 7000 lx: below 3 ~ 6 cm of a fluorescent lamp or a 60 watt incandescent lamp).

#### 3. Charge Demand Display (C.D.D.)

When the capacitor is nearly discharged, the second hand starts moving at two-second intervals to indicate that charging is required. The watch still works for about 15 hours from this state. Therefore, the watch can be left uncharged over night.

#### 4. Over-charging prevention function

When the capacitor is charged and its voltage reaches 1.8V, the over-charging prevention function operates to prevent from capacitor deterioration and damage.

### «Notes on servicing»

#### 1. Capacitor replacement

If a silver oxide battery is erroneously loaded in this watch and it is charged, the battery may explode. When replacing the capacitor, be sure to check with the mark "capacitor". Therefore, the watch is made so that the capacitor is not replaced easily.

#### 2. Solar battery



The solar battery is the base of the glass plate. Take care not to damage it. Especially, when removing the hands, do not use the solar battery as a support.

## II. SPECIFICATIONS

Cal. No.		V103A	V102A
Item		Three hands	
Indication system		Three hands	
Additional mechanism		Day date	Date
		Day and date quick resetting device	Date quick resetting device
		Second setting device	
		Electronic reset switch	
		Capacitor Charge Demand Display (second hand moves at two-second intervals)	
Loss/gain		Monthly rate: less than 20 seconds at normal temperature range (except when second hand moves at two-second intervals)	
Movement size	Size of main plate	ø26.4 mm x 23.5 mm (3H - 9H) (Max. diameter: 28 mm)	
	Casing diameter	ø25.6 mm x 23.5 mm	
	Height	3.59 mm	3.31 mm
Regulation system		None	
Quartz Tester measuring gate		10-second gate	
Capacitor		EECW 1R8E334 (Matsushita), MC 11620 (Hitachi Maxell)	
Jewels		3 jewels	

## III. LIST OF SCREWS USED

In Cal. V10 series, two kinds of screws are used. When disassembling or reassembling, classify the screw referring to the table below.

Type	Parts No.	Parts name	Screw classification
			Screw head diameter
	002 247	Train wheel bridge screws ..... 2 pcs. Setting lever spring screw ..... 1 pce. Battery connection (-) screw ..... 1 pce. Battery connection (+) screws ..... 4 pcs.	Larger
	022 248	Date dial guard screw ..... 3 pcs	Smaller

#### IV. STEP MOTOR LOAD-COMPENSATIVE DRIVING PULSE SYSTEM (Special motor drive circuit with a low power consumption)

● In the conventional analogue quartz watch, the width of a driving pulse supplied to the step motor is constant. (Fig. 1)

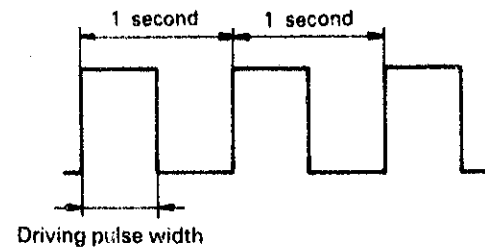

Fig. 1

● In the Cal. V10, the width of a driving pulse changes according to the load required to drive the watch. A pulse of a minimum necessary width is supplied to the step motor to drive the hands under normal conditions, but when the watch load (to drive calendar, or at a low ambient temperature) is increased, a pulse of a large width necessary to overcome the load is supplied (Fig. 2). Therefore, this feature is effective to economize power consumption. (For checking of the current consumption, refer to page 12.)

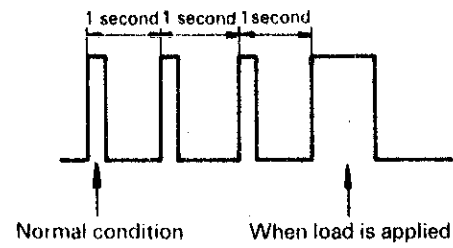
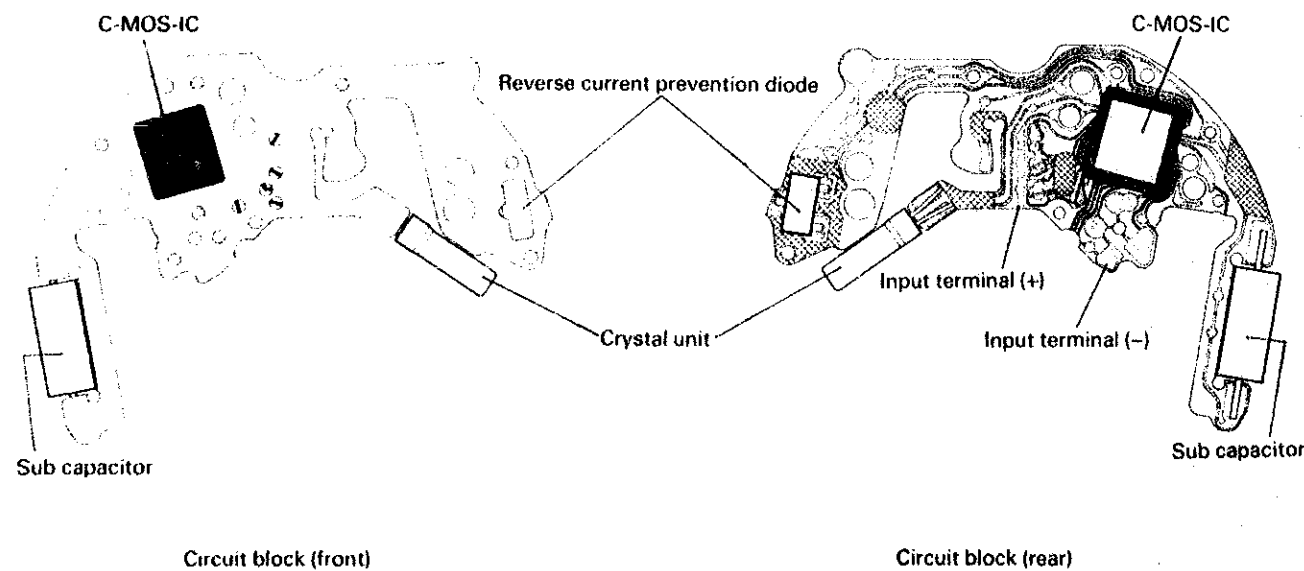

Fig. 2

#### V. STRUCTURE OF CIRCUIT BLOCK



#### VI. DISASSEMBLING, REASSEMBLING AND LUBRICATING

##### (1) Disassembly and reassembly of casing parts

● According to the model of Cal. V10 series, the mounting method of the solar battery differs. (Circular case)

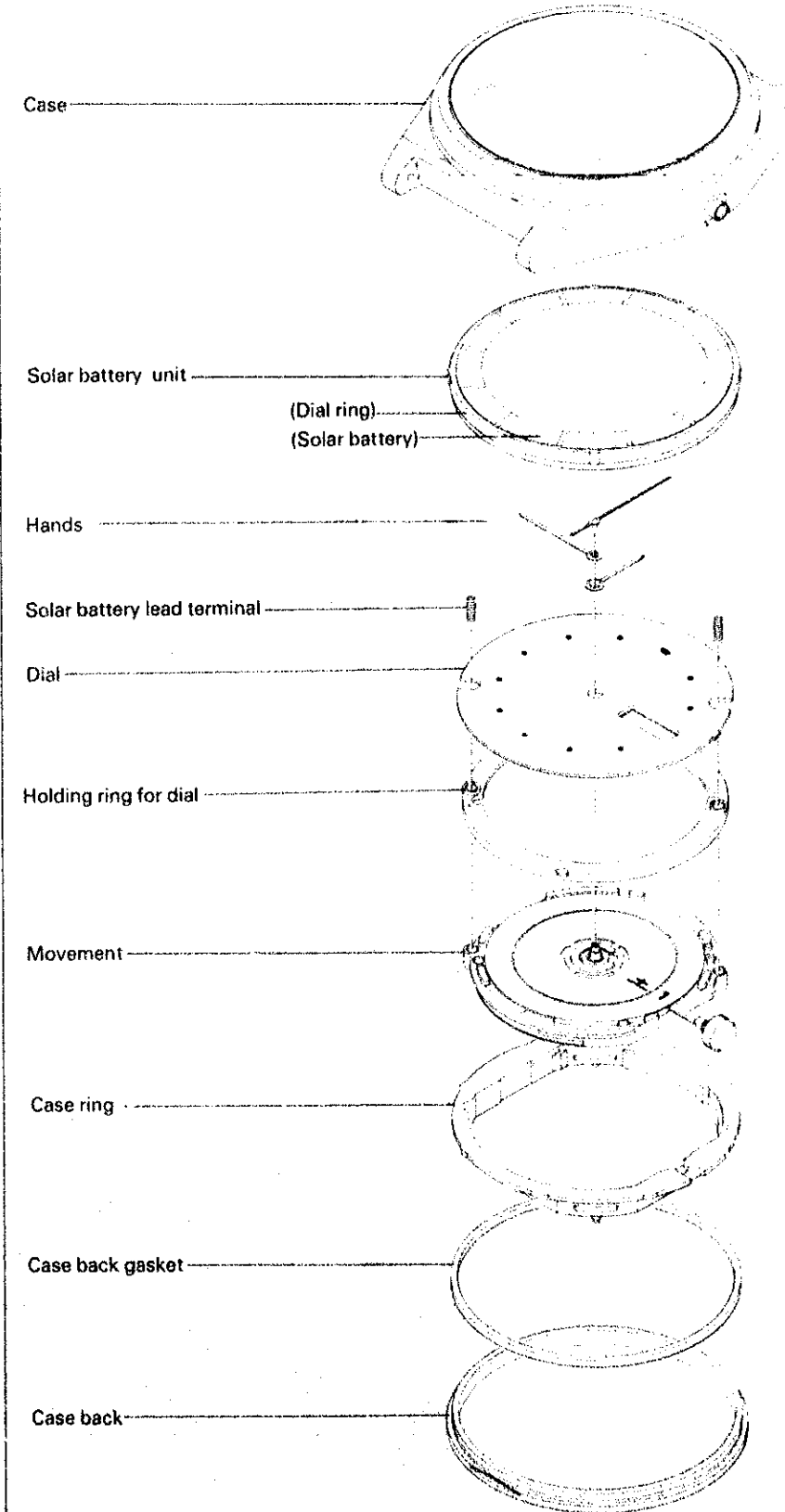

**Note:** Solar battery unit  
The solar battery and the dial ring are fixed with adhesive tape. Do not peel off.

(Square case)

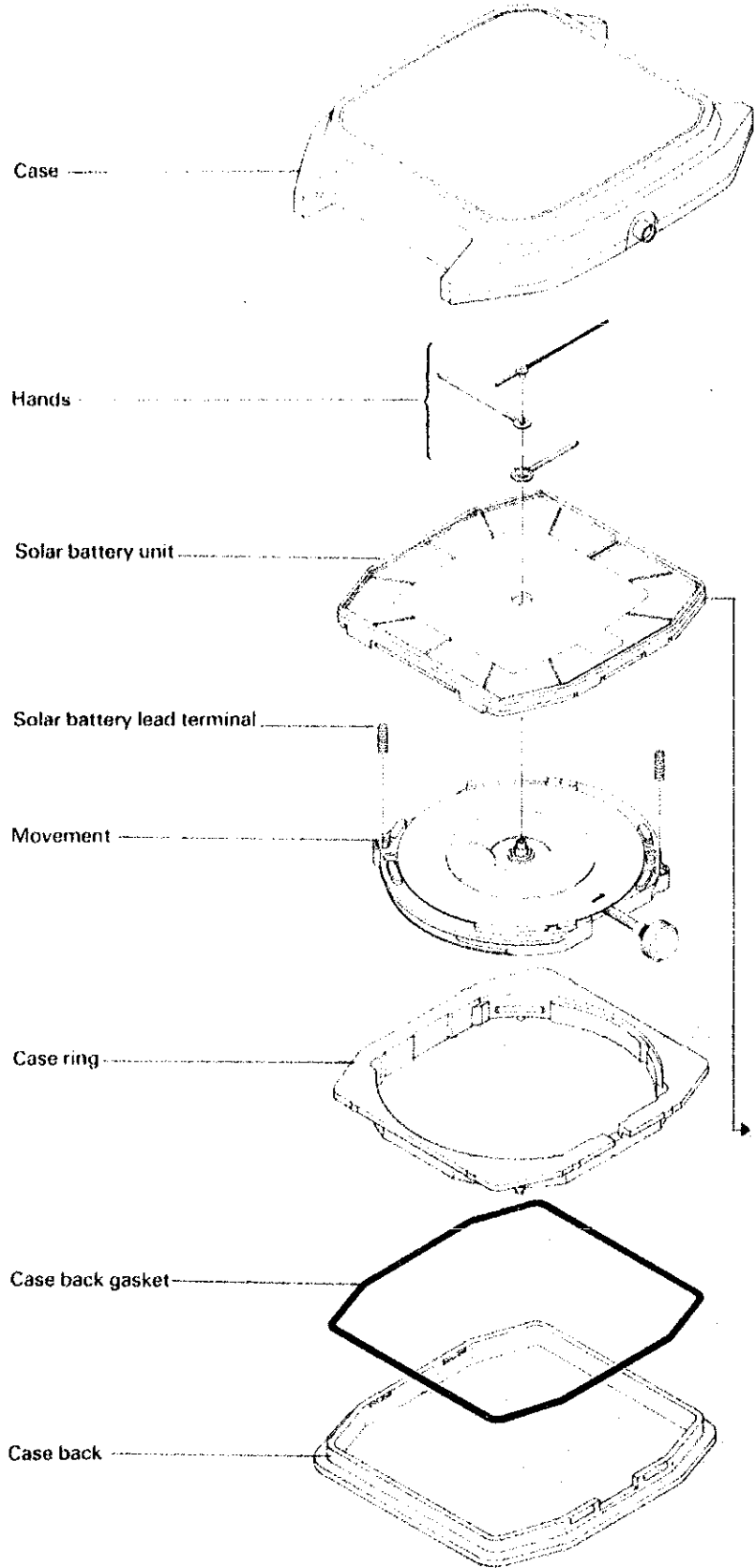

**Note: Solar battery crack**  
When removing the hands, take care not to apply excessive force to the solar battery. Doing so may damage the solar battery.

**Note: Solar battery unit**  
The solar battery and dial are fixed by the dial frame. Carefully handle the solar battery unit as it is liable to be damaged.

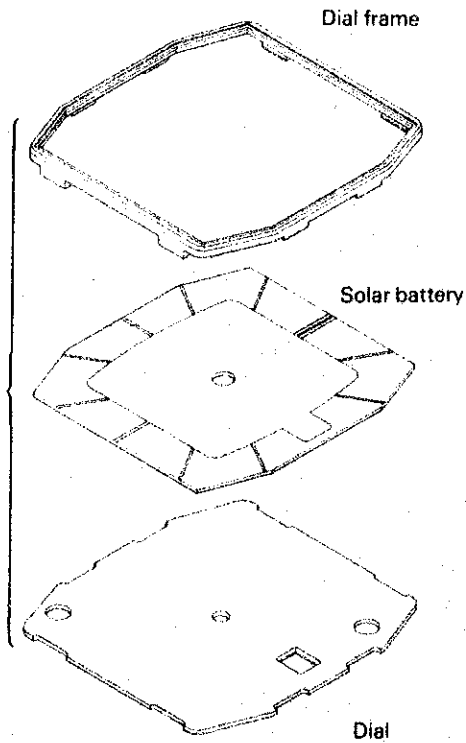

Disassembly procedures: ① ~ ⑭  
Reassembly procedures: ⑭ ~ ①

**(2) Calendar mechanism**

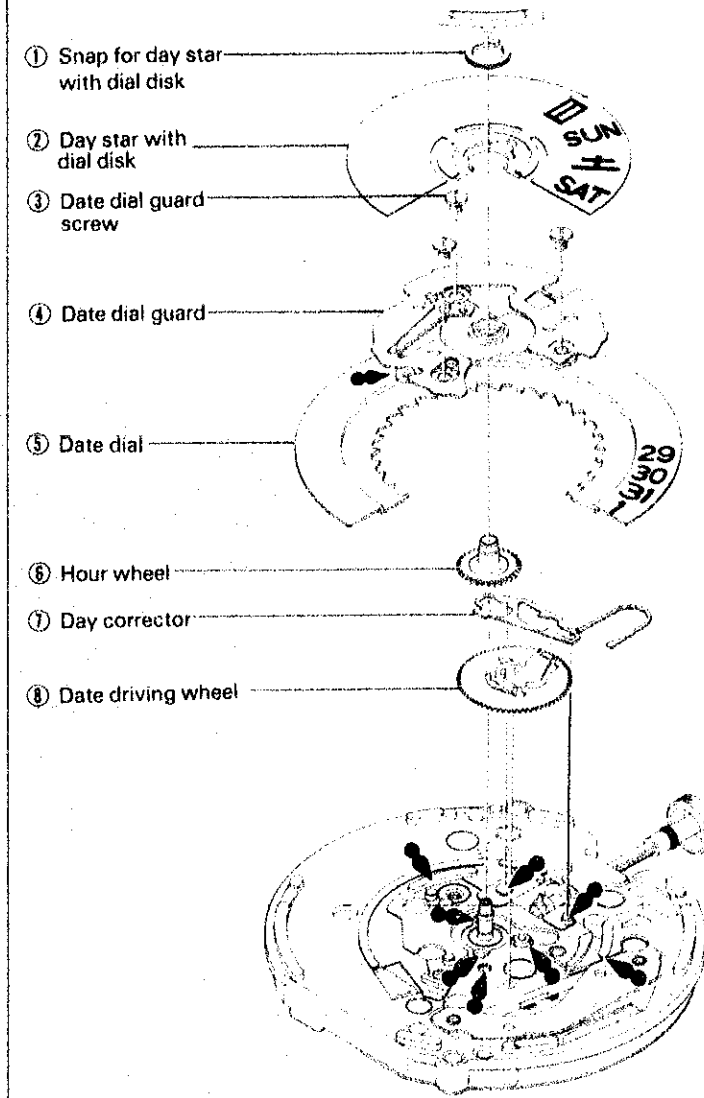

Lubricating:

Types of oil
Moebius A ●

● Movement Holder  
Use the universal movement holder.

**Note:**  
When installing the day corrector ⑦ hook the tail of the spring with the main plate as shown below.

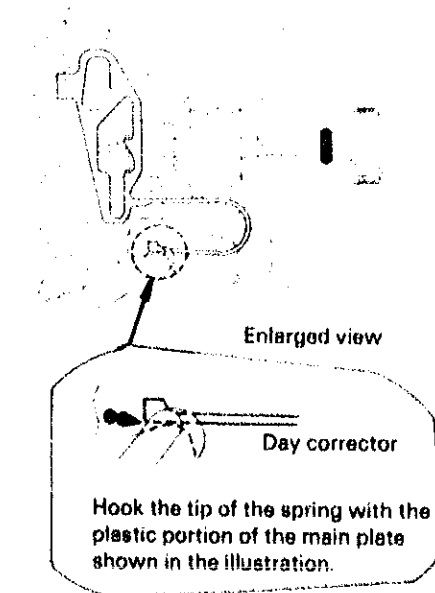

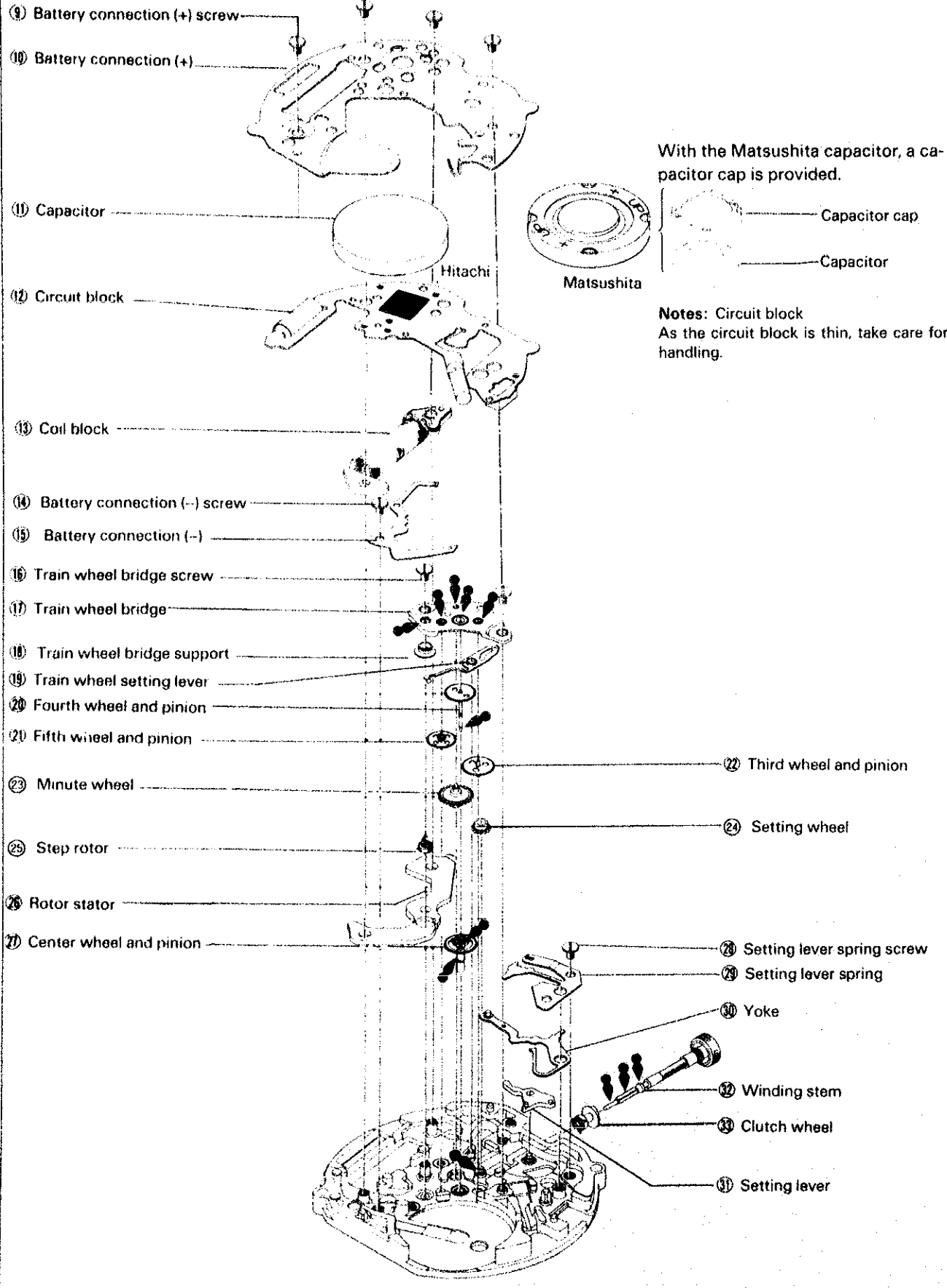

**(3) Circuit block · Drive coil · Train wheel, Selector mechanism**

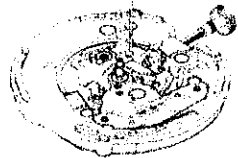

**VII. CLEANING**

**How to clean**

Name of parts	Cleaning	Drying	Solution	Remarks
<ul style="list-style-type: none"> <li>Main plate</li> </ul> 	<ul style="list-style-type: none"> <li>Rinse or wash with a soft brush.</li> </ul>	<ul style="list-style-type: none"> <li>Warm air drying</li> </ul>	<ul style="list-style-type: none"> <li>Benzine</li> <li>DIFLON S-3</li> <li>Alcohol</li> </ul>	<ul style="list-style-type: none"> <li>Be careful not to deform or remove the parts fixed to the main plate.</li> </ul>
<ul style="list-style-type: none"> <li>Step rotor</li> </ul> 	↑	↑	↑	<ul style="list-style-type: none"> <li>Use a clean solution as the step rotor is magnetized and may attract foreign metal particles. Any foreign matter which cannot be removed by cleaning should be removed with Rodico.</li> </ul>
<ul style="list-style-type: none"> <li>Plastic parts</li> </ul>	↑	↑	↑	<ul style="list-style-type: none"> <li>When cleaning with benzine, the cleaning time should be minimized.</li> </ul>
<ul style="list-style-type: none"> <li>Other parts (excluding parts that must not be cleaned.)</li> </ul>	<ul style="list-style-type: none"> <li>Clean with a cleaner, rinse or gently scrub with a soft brush.</li> </ul>	<ul style="list-style-type: none"> <li>Warm or hot air drying</li> </ul>	<ul style="list-style-type: none"> <li>Benzine</li> <li>Trichroethylene</li> <li>DIFLON S-3</li> </ul>	

**Parts that must not be cleaned**

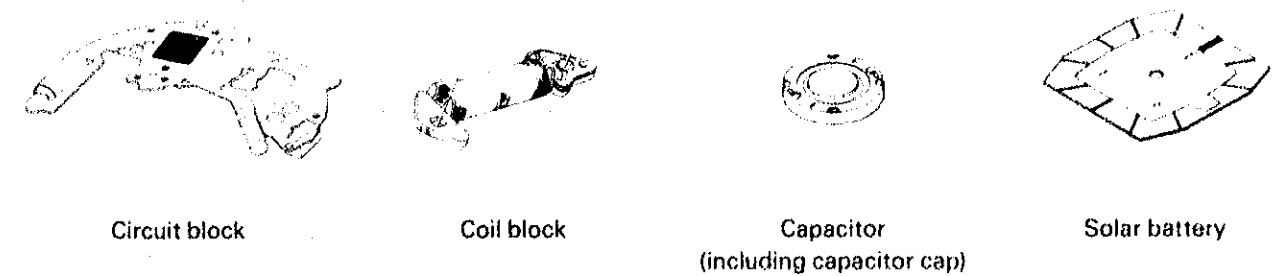

● Be sure to clean only stains on the conductive portions of circuit block, etc. with a cloth moistened with benzine, DIFLON S-3 or alcohol and dry them with warm air.

## VIII. CHECKING AND ADJUSTMENT

### (1) Guide table for checking and adjustment

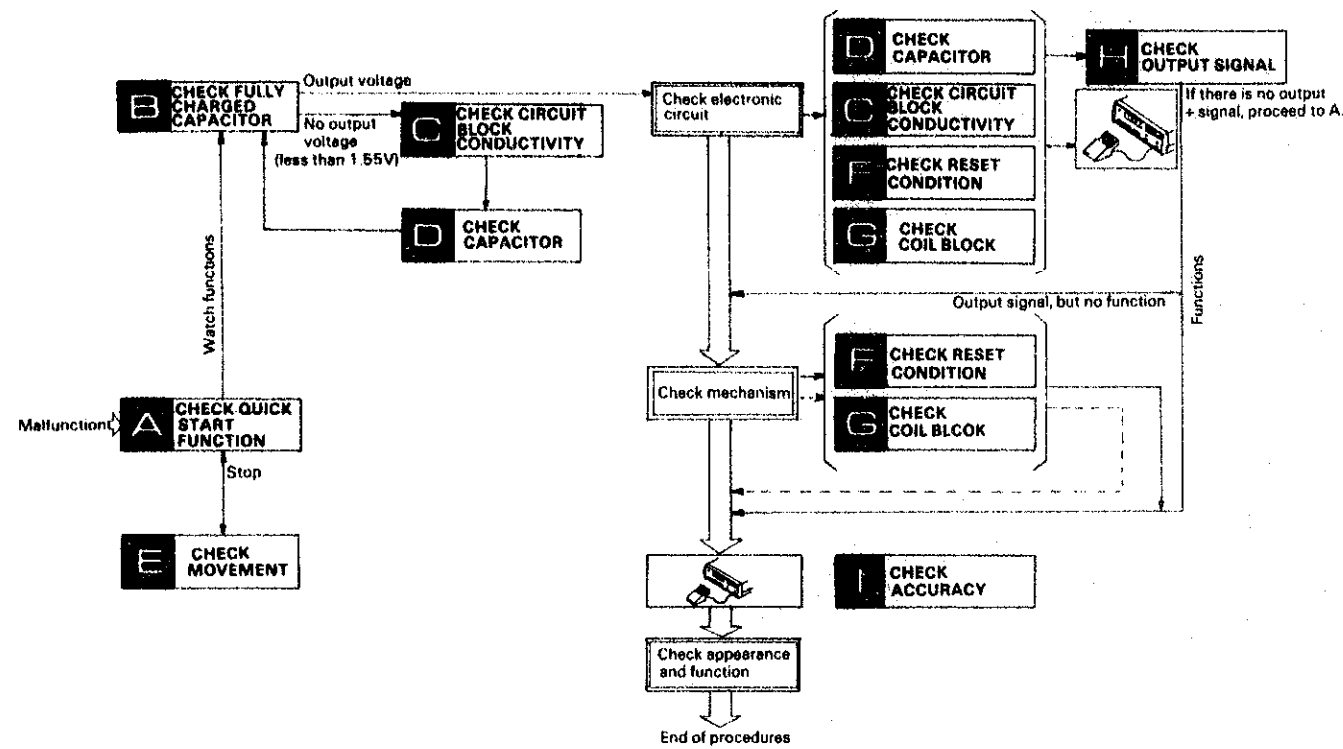

### (2) Procedures for checking and adjustment

#### A QUICK START FUNCTION

Check that watch starts functioning after illumination.

- (1) Illuminate the watch (the solar battery portion) 5 cm under the fluorescent light (15 ~ 20W) as shown in the right figure.

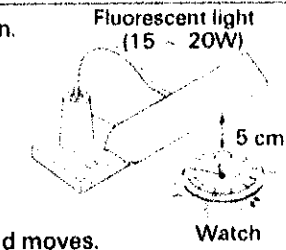

Result:

- Hand moves.....Normal
  - Hand does not move.....Defective
- Check the conductivity of solar battery lead terminal and replace circuit block.  
Hand moves.....Normal  
Hand does not move.....Defective  
Check movement (Proceed to E)

- (2) After 10 second illumination, check that the hand moves.

#### B FULLY CHARGED CAPACITOR

Check the capacitor when it is fully charged.

- (1) To charge the capacitor fully, illuminate the watch (the solar battery portion) 5 cm under the fluorescent light (15 ~ 20W) for 3 hours as shown in the right figure.
- (2) Check the capacitor voltage.
  - Remove the capacitor cap.
  - Set up the Digital Multi-Tester (S-840A). (Range to be used: DCV)
  - Measurement Red probe (+) ... Capacitor (+) surface  
Black probe (-) ... Capacitor (-) surface

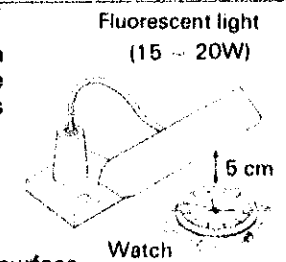

Result:

- More than 1.55V.....Normal
- Check the electronic circuit
- Less than 1.55V.....Defective
- Check circuit block conductivity

#### C CIRCUIT BLOCK CONDUCTIVITY

Check the circuit block for conductivity or conductivity.

- (1) Check the battery connection (+) screw for loose.
- (2) Check for inferior soldering, short circuit, contamination and poor contact.

Result:

- (1) No loose.....Normal  
Loosed screw.....Retighten the screw.
- (2) Conductive.....Normal  
No conductivity.....Remove the contamination.  
If steps (1) and (2) executed are normal and the voltage of the capacitor fully charged is still below 1.55V, replace the circuit block.

#### D CAPACITOR

Check the capacitor.

- (1) Check the capacitor for assembling direction. ⊕ polarity → upper  
⊖ polarity → lower
- (2) Check the capacitor for conductivity.  
Check for short circuit, contamination and poor contact.  
Check the battery connection (+) screw for loose.
- (3) Check the capacitor for leakage.

Result:

- (1) Correctly assembled.....Normal  
Incorrectly assembled.....  
Reassemble correctly
- (2) Correct conductivity.....Normal  
No conductivity.....Remove the contamination and retighten the screw.
- (3) No leakage.....Normal  
\*Leaked.....Defective  
If steps (1), (2) and (3) executed are normal, and the voltage of the battery is still below 1.55V, replace the capacitor and proceed to B.  
If the check done in B results in no output voltage (less than 1.55V), replace the solar battery.

\*Refer to next page "If the capacitor leakage is found"

### \*IF THE CAPACITOR LEAKAGE IS FOUND

#### Procedure

- (1) Disassemble the movement.
- (2) Wipe off the leaked electrolyte from the circuit block.
  1. Moisten the cloth with distilled water. If distilled water is not available, use tap water.
  2. Wipe the circuit block with a cloth moistened with alcohol. (If the cleaned portions remain wet with water, they will corrode with rust.)
  3. Dry with warm air by using a dryer.
- (3) Clean other parts which come into contact with the capacitor electrolyte by following the steps described in "CLEANING" on page 8.
- (4) Reassemble the movement. (Replace the capacitor with a new one.)
- (5) Check that the watch functions and the current consumption is normal.

### E MOVEMENT

#### Check the movement function.

- (1) Remove the capacitor.
  - (2) Load the temporary battery (SR1120SW or TR1120SW) and assemble the battery connection (+).
  - (3) Check the movement function.
- Note:** After movement check, be sure to remove the temporary battery and set the capacitor again.

#### Result:

Functions.....After replacing the solar battery, proceed to A.  
Does not function.....After replacing the movement, proceed to A.

### F RESET CONDITION

#### Check that the reset condition is normal.

- (1) Check that the second hand stops completely when the crown is fully pulled and it starts moving when the crown is pushed into the normal position after 1 second. (Check the output signal with a Quartz Tester or check with the second hand installed.)
- (2) The operation of the train wheel setting lever can be observed through the hole in the train wheel bridge as shown in the right illustration.
  - Ⓐ When the crown is fully pulled, the spring of the train wheel setting lever can be seen through the hole in the train wheel bridge (the spring can be seen 1/3 of the hole).
  - Ⓑ When the crown is pushed into the normal position, the spring of the train wheel setting lever cannot be seen through the hole in the train wheel bridge.
- (3) Check the output signal when the crown is fully pulled.

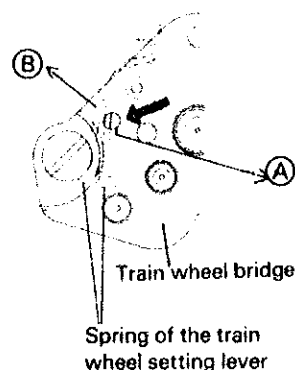

#### Result:

(1) Functions correctly.....Normal  
Does not function.....Defective  
Check the electronic circuit.

(2) Correct (figure Ⓐ, Ⓑ): Normal  
Fault : Defective  
Replace the train wheel setting lever.

(3) No output signal.....Normal  
Output signal.....Defective  
Replace the circuit block.

### G COIL BLOCK

#### Check the coil block for broken wire and short circuit.

1. Set up the Digital Multi Tester (S-840A).  
Range to be used:  $\Omega$
2. Checking  
Apply the black and red probes to the lead plates of the coil block. (Either red or black probes will do.)



2.0 k $\Omega$  ~ 2.5 k $\Omega$ .....Normal

More than 2.5 k $\Omega$  (Broken wire)  
Less than 2.0 k $\Omega$  (Short circuit)  
.....Defective  
Replace the coil block.

### H OUTPUT SIGNAL

#### Check for output signal.

1. Use the Quartz Tester.
2. Check to see if the input indicator light blinks.

#### NOTE:

- Checking should be made with the crown set to normal position.
- The US-32 timing microphone cannot be used.

#### Result:

Output signal: Normal (One-second blinking)  
No output signal: Proceed to A (No one-second blinking)

### I ACCURACY

#### Check gain and loss of time using Quartz Tester (10-second) and an electromagnetic microphone (DM-1).

#### NOTE:

- Check accuracy with the crown at normal position.
- The US-32 timing microphone cannot be used.
- Do not measure during two second intervals operation.

#### Result:

Monthly rate (at normal temperature range)  
Less than 20 seconds: Normal  
More than 20 seconds: Defective  
Replace the circuit block

### J CURRENT CONSUMPTION

#### Check the current consumption of the movement with Digital Multi Tester S-840A.

1. Set up the Digital Multi Tester S-840A. (Mode:  $\mu A$ )
2. Remove the capacitor.
3. Assemble the battery connection (+).
4. Insulate the battery connection (+) and battery connection (-).

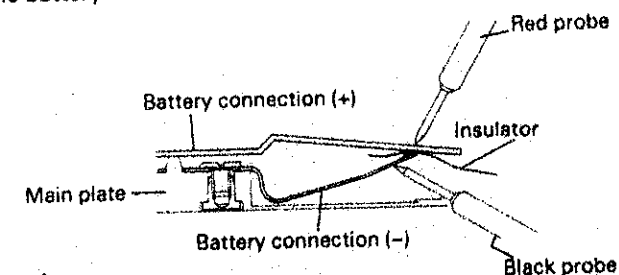

#### 5. Measurement

- Red probe (+).....Battery connection (+)  
Black probe (-).....Battery connection (-)

The current consumption should be measured in the normal hand driving condition (when extra load is not applied). Before measuring the current consumption, pull the crown several times to reset the watch while the probes are applied.

#### NOTE:

When measuring the current consumption under the incandescent lamp, cover the movement with black cloth. Otherwise the measured value sometimes becomes higher than the actual value.

#### Result:

Less than 1.5  $\mu A$ .....Normal

More than 1.5  $\mu A$ .....Defective  
Check the electronic circuit.

(Revised)

# PARTS LIST

## CAL. V102A & V103A

Cal. V102 A		★ Cal. V103 A	
PARTS NO.	PARTS NAME	PARTS NO.	PARTS NAME
125 755	Train wheel bridge	125 755	Train wheel bridge
* 221 795	Center wheel & pinion	221 755	Center wheel & pinion
* 221 755	Center wheel & pinion	231 755	Third wheel & pinion
231 755	Third wheel & pinion	241 765	Fourth wheel & pinion
* 241 795	Fourth wheel & pinion	261 755	Minute wheel
* 241 765	Fourth wheel & pinion	271 765	Hour wheel
261 755	Minute wheel	281 755	Setting wheel
* 271 795	Hour wheel	282 761	Clutch Wheel
* 271 765	Hour wheel	* 354 765	Winding stem
281 755	Setting wheel	383 755	Setting lever
282 763	Clutch wheel	384 755	Yoke
* 354 765	Winding stem	388 765	Setting lever spring
383 755	Setting lever	391 755	Train wheel setting lever
384 755	Yoke	426 740	Train wheel bridge support
388 765	Setting lever spring	* 470 . . .	Day star with dial disk
391 755	Train wheel setting lever	701 755	Fifth wheel & pinion
426 740	Train wheel bridge support	719 755	Day corrector
701 755	Fifth wheel & pinion	* 801 538	Date dial
* 801 578	Date dial	* 801 622	Date dial
802 756	Date driving wheel	802 755	Date driving wheel
808 756	Date dial guard	808 755	Date dial guard
* 3029 001	Capacitor	963 781	Snap for day star with dial disk
4001 502	Circuit block	* 3029 001	Capacitor
4002 500	Coil block	4001 502	Circuit block
4146 755	Step rotor	4002 500	Coil block
4239 500	Rotor stator	4146 755	Step rotor
4270 755	Battery connection (-)	4239 500	Rotor stator
4271 788	Battery connection (+)	4270 755	Battery connection (-)
4246 511	Solar battery lead terminal	4271 786	Battery connection (+)
* 4414 500	Capacitor cap	4246 510	Solar battery lead terminal
022 247	Train wheel bridge screw	* 4414 500	Capacitor cap
022 247	Battery connection (-) screw	022 247	Train wheel bridge screw
022 247	Battery connection (+) screw	022 247	Battery connection (-) screw
022 247	Setting lever spring screw	022 247	Battery connection (+) screw
022 248	Date dial guard screw	022 247	Setting lever spring screw
* 4020 . . .	Solar cell	022 248	Date dial guard screw
* 4025 . . .	Solar cell	* 4020 . . .	Solar cell
		* 4025 . . .	Solar cell

**Remarks:**

\* Winding stem

The type of winding stem is determined based on the design of case.

\* Date dial

Cal. No.	Parts No.	Specification
V102A	801650	White figures on black background
	801578	Black figures on white background
V103A	801622	Black figures on white background
	801538	White figures on black background

Used for both the crown and calendar frame at 3 o'clock position.

If any other type of date dial is required, specify ① Cal. No. ② The crown position ③ the calendar frame position and ④ Dial No.

★ PLEASE NOTICE THAT THE PARTS NUMBER 4447508 (ADHESIVE TAPE FOR SOLAR CELL) WILL BE SUPPLIED ONLY IN THE CAL. V103A.

**\* Capacitor, Capacitor Cap**

As the capacitor cap is to be used or not in accordance with makers, refer to the table below.

Maker	Capacitor	Capacitor cap
HITACHI	3029002	—
MATSUSHITA	3029001	4414500

**\* Day star with dial disk (V103A)**

Parts No.	Combination of language	Ground color	Figure color
470605	English + Spanish	White	Black
470642	English + Spani . . .	Black	White
470606	English + French	White	Black
470643	English + French	Black	White
470607	English + Italian	White	Black
470644	English + Italian	Black	White
470608	English + Japanese	White	Black
470627	English + Japanese	Black	White
470609	English + Roman Numeral	White	Black
470645	English + Roman Numeral	Black	White
470610	English + Arabic	White	Black
470646	English + Arabic	Black	White
470611	English + German	White	Black
470647	English + German	Black	White

Used for both crown and calendar frame at 3 o'clock position.

If any other type of day star with dial disk is required, specify the number printed on the disk.

**\* Solar cell**

The type of solar cell based on the design of case. Please refer to Casing Parts Catalogue.

**\* Center wheel & pinion, Fourth wheel & Pinion, Hour wheel**

There are two different types as specified below.

Combination:

*Type	Center wheel & pinion	Fourth wheel & pinion	Hour wheel
M	221795	241795	271 795
S	221755	241765	271 765

\* abbreviation M..... Standard type (Movement type) S..... Short type