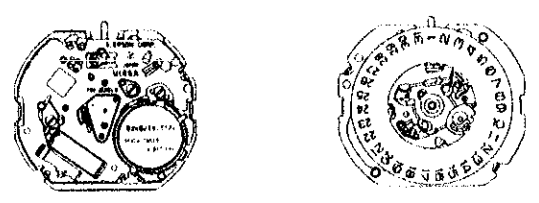

# PARTS CATALOGUE/TECHNICAL GUIDE

## Cal. V145A

### [SPECIFICATIONS]

Item	Cal. No.	V145A
Movement		
		(x 1.0)
Movement size	Outside diameter	ø25.0 mm 24.0 mm between 6 o'clock and 12 o'clock sides 21.3 mm between 3 o'clock and 9 o'clock sides
	Casing diameter	ø24.0 mm 23.3 mm between 6 o'clock and 12 o'clock sides 19.3 mm between 3 o'clock and 9 o'clock sides
	Height	3.0 mm (Including the battery portion)
Time indication		3 hands
Driving system		Step motor (Load compensated driving pulse type)
Additional mechanism		<ul style="list-style-type: none"> <li>• Solar power system</li> <li>• Overcharge prevention function</li> <li>• Energy depletion forewarning function</li> <li>• Quick-start function</li> <li>• Electronic circuit reset switch</li> <li>• Train wheel setting device</li> <li>• Date calendar</li> <li>• Instant setting device for date calendar</li> </ul>
Loss/gain		Monthly rate at normal temperature range: less than 20 seconds
Regulation system		Nil
Measuring gate by quartz tester		Use 10-second gate.
Power supply	Power generator	Solar power system
	Rechargeable battery	Titanium-lithium ion rechargeable battery
Operating voltage range		0.45 ~ 2.20 V
Expected life per charge		From full charge to stoppage: Approx. 6 months
Jewels		2 jewels

SEIKO CORPORATION

# PARTS CATALOGUE

Cal. V145A

Disassembling procedures Figs. : ① → ③④

Reassembling procedures Figs. : ③④ → ①

Lubricating: Types of oil      Oil quantity  
 Moebius A       Normal quantity

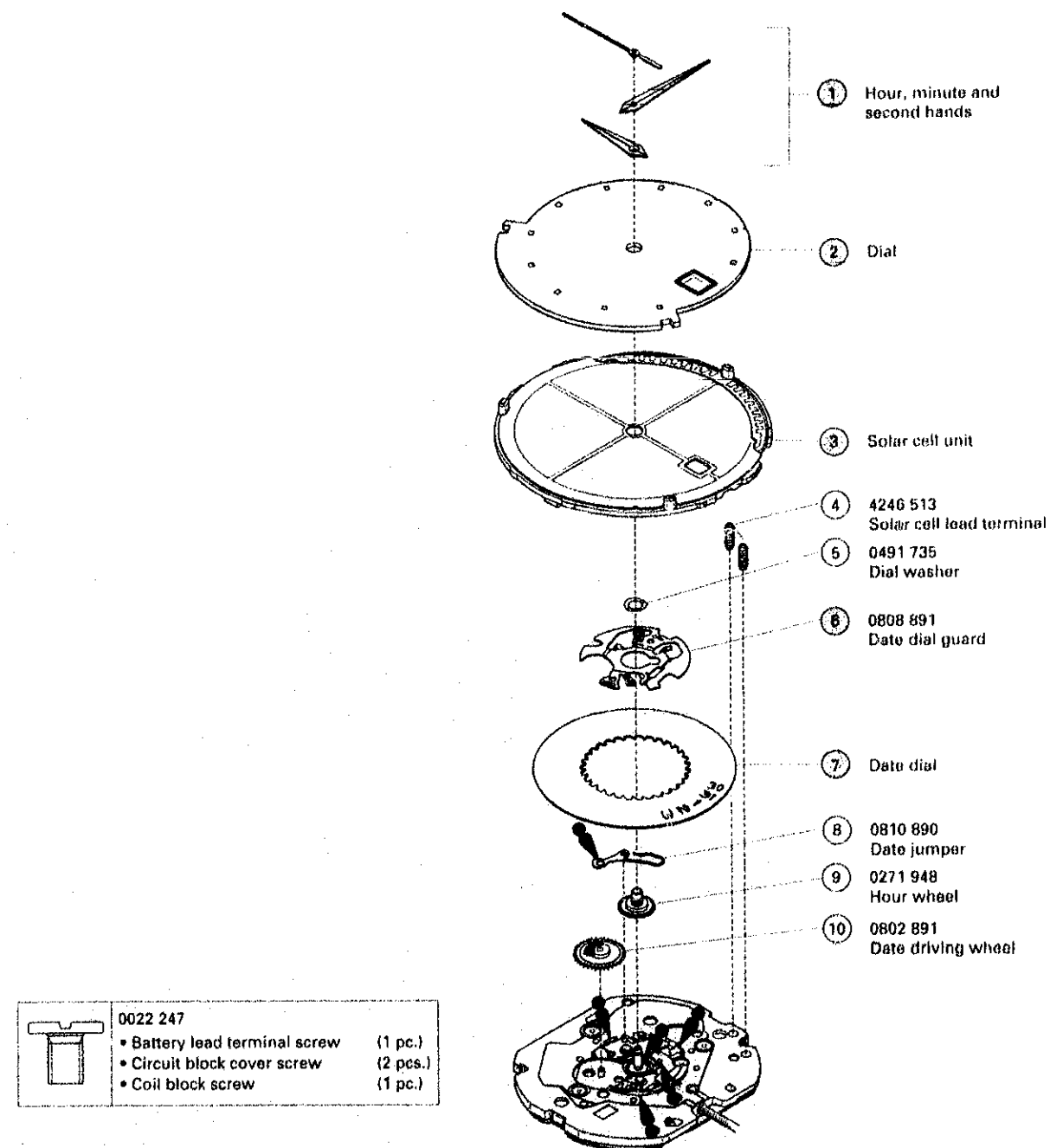

 Please see the remarks on the following pages.

# PARTS CATALOGUE

Cal. V145A

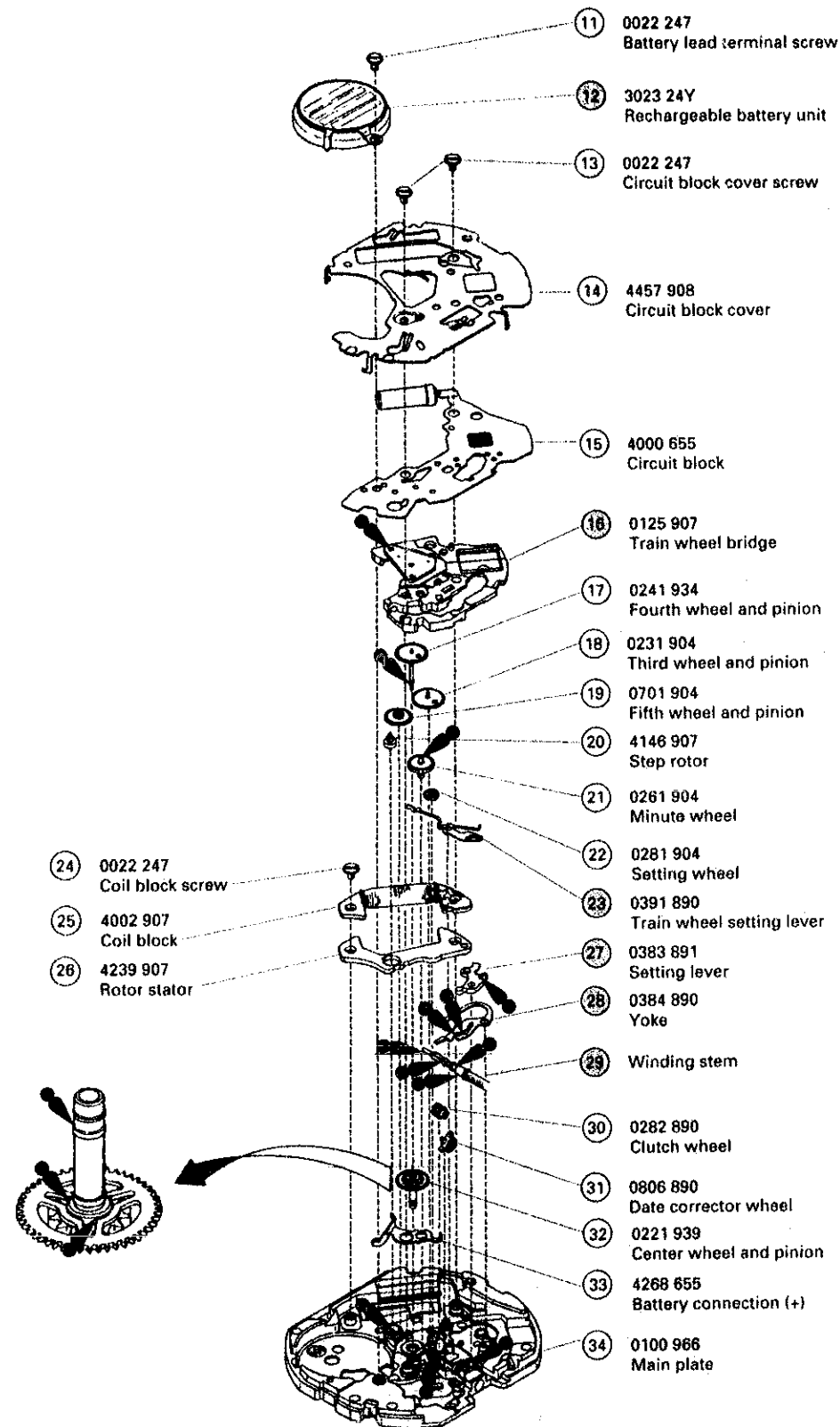

⊙ ⇨ Please see the remarks on the following pages.

# PARTS CATALOGUE

Cal. V145A

## Remarks:

⊙ 3 Solar cell unit (with holding ring for dial) 4020 572

As the solar cell unit is set to the holding ring for dial with glue, its type is determined based on the design of cases. Check the case number and refer to "PULSAR Casing Parts Catalogue" to choose a corresponding solar cell unit.

⊙ 7 Date dial

Part code	Position of crown and calendar frame	Color of figure	Color of background
0878 905	3 o'clock	Black	White

The type of date dial is determined based on the design of cases. Check the case number and refer to "PULSAR Casing Parts Catalogue" to choose a corresponding date dial.

⊙ 29 Winding stem 0351 892

The type of winding stem is determined based on the design of cases. Check the case number and refer to "PULSAR Casing Parts Catalogue" to choose a corresponding winding stem.

- The explanation here is only for the particular points of Cal. V145A.
- For the repairing, checking and measuring procedures, refer to the "TECHNICAL GUIDE, GENERAL INSTRUCTIONS".

## I. STRUCTURE OF THE CIRCUIT BLOCK

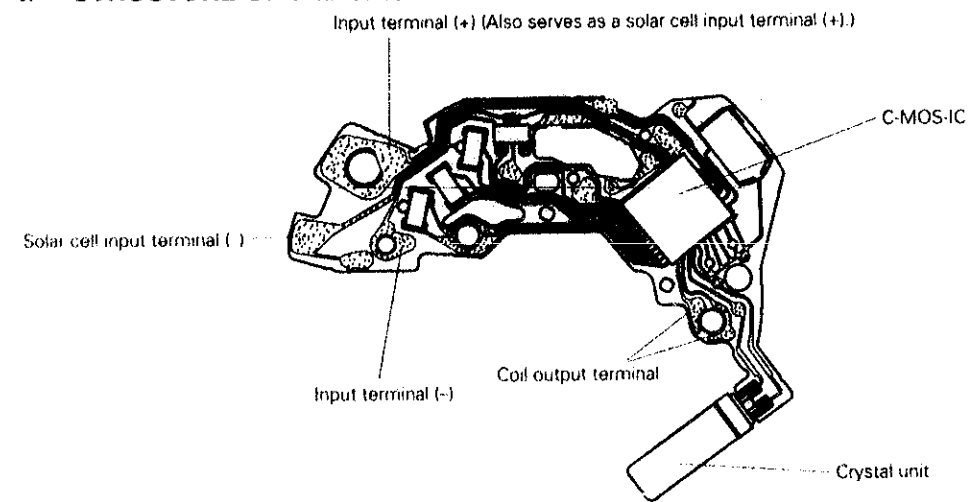

## II. REMARKS ON DISASSEMBLING AND REASSEMBLING

### ① Hands

#### • How to install

Place the movement directly on a flat metal plate or the like to install the hands. In doing so, check that the spring portion of the circuit block cover is not pressed down.

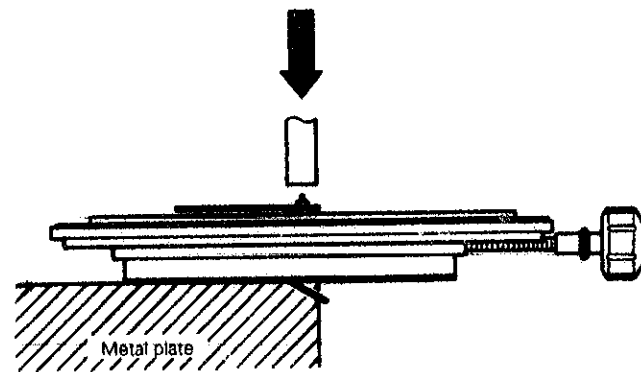

### ② Dial

#### • How to install

Set the notched portions of the dial to the guide posts at the 4 o'clock and 8 o'clock sides of the solar cell unit, and check that the dial is fixed in position.

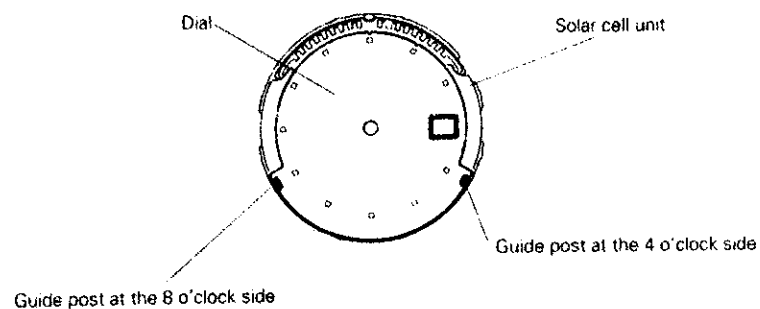

### ③ Solar cell unit

#### • How to remove

- The solar cell unit is fixed by two hooking portions at the 12 o'clock and 6 o'clock sides.
- Insert the tip of a screwdriver into a gap between the hooking portion and main plate as shown in the illustration, and then, turn the screwdriver in the direction of the arrow to release the hooking portion from the main plate.

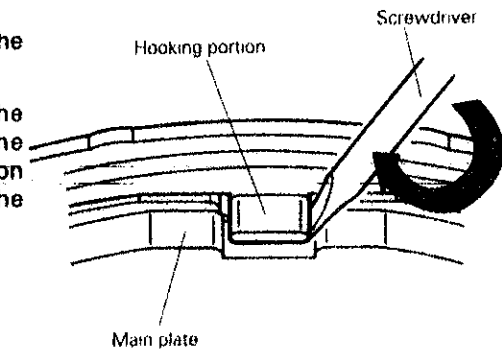

#### • How to install

- Set the hooking portions at the 12 o'clock and 6 o'clock sides to the main plate.
- Gently push the solar cell unit above the hooking portions so that they catch the main plate securely.

- Notes:**
- When installing the solar cell unit, take care not to damage or deform the solar panel.
  - After installing the solar cell unit, check that both the hooking portions catch the main plate securely.

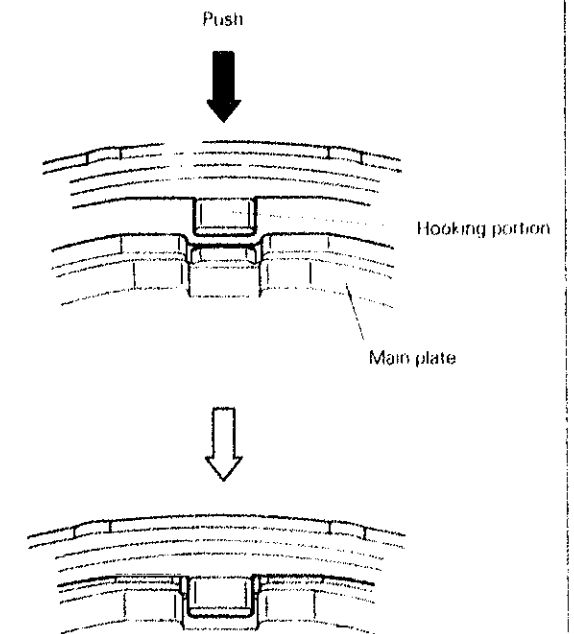

# TECHNICAL GUIDE

Cal. V145A

## 6 Date dial guard

Unlike conventional movements, the date dial guard is not fixed with screws. It is set to the main plate with three protrusions, which are caught under the main plate by turning the guard. Then, it is fixed by two guide pins.

### • How to remove

- 1) Lightly lift the "A" portion of the date dial guard with tweezers to release it from the guide pin, and then move it counterclockwise until it mounts on the guide pin.
- 2) Release the "B" portion of the date dial guard in the same way as described above, and then move it counterclockwise until it mounts on the guide pin.
- 3) Check that all the three protrusions of the date dial guard have come off from the main plate, and then remove the date dial guard.

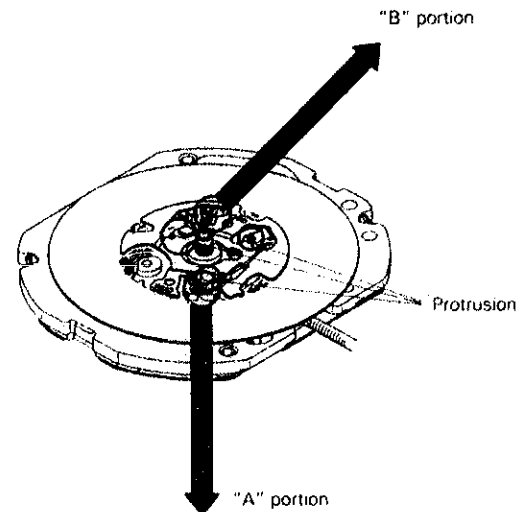

### • How to install

- 1) Put the date dial guard on the main plate so that the "A" and "B" portions are over the guide pins, as shown in the illustrations at right.
- 2) Move the protrusion "D" of the date dial guard clockwise so that it is caught under the main plate.
- 3) Slightly move the protrusions "C" and "E" clockwise alternately to set them under the main plate. Then, set the "A" and "B" portions of the date dial guard to the guide pins.
- 4) Check that the date dial guard is fixed securely to the main plate.

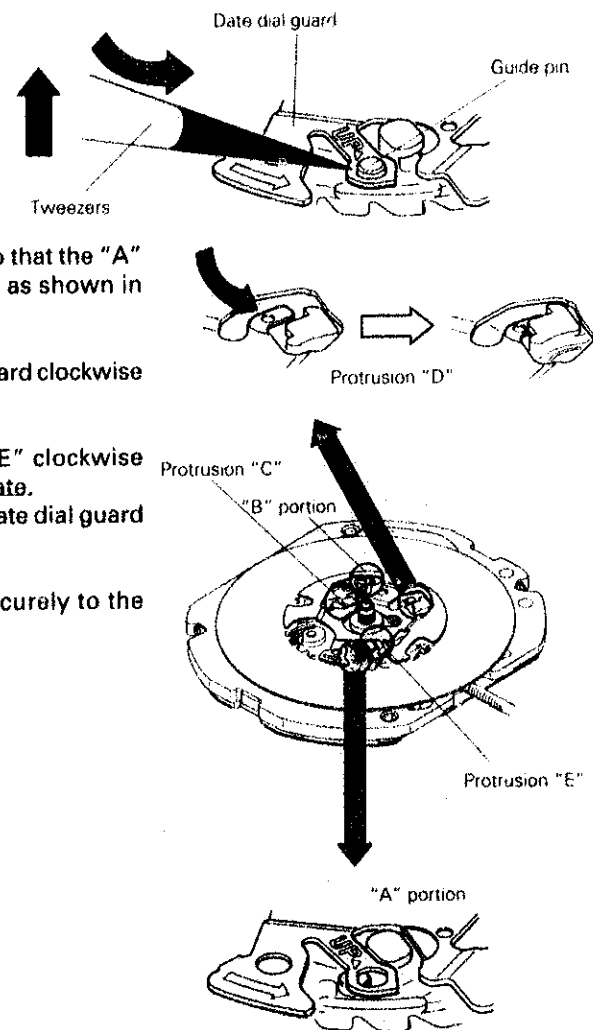

# TECHNICAL GUIDE

Cal. V145A

## 12 Rechargeable battery unit

### • How to remove

- Remove the battery lead terminal screw, and then pry up the "A" portion in the illustration with tweezers to remove the rechargeable battery unit.

### • How to install

- Set the "B" portion of the battery lead terminal to the guide hole of the main plate, and then push the center portion of the rechargeable battery unit (the "C" portion in the illustration) to fix it in position.

- Notes:**
- Be sure to observe the correct polarity of the rechargeable battery unit. The (-) side has the lead terminal.
  - Handle the rechargeable battery unit with care so as not to short-circuit its (+) and (-) terminals.

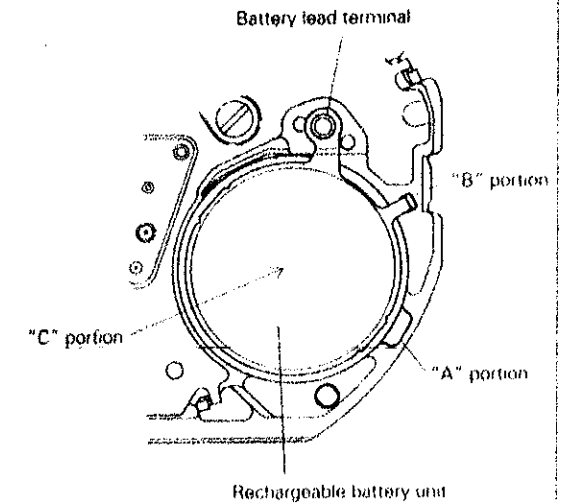

## 16 Train wheel bridge

### • Setting position

Refer to the illustrations below to check where to install the respective wheels.

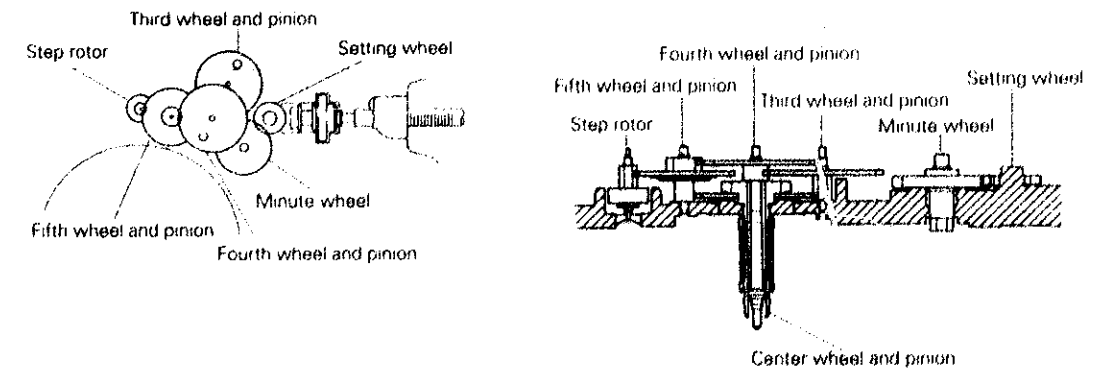

## 23 Train wheel setting lever

## 27 Setting lever

## 28 Yoke

### • Setting position

Refer to the illustration at right.

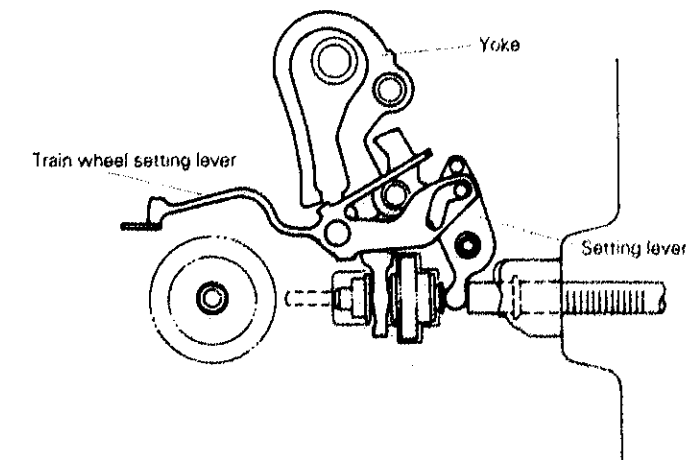

29 Winding stem

- The date corrector wheel has some elasticity in the contact with the winding stem so that it can be easily fixed.
- Push in the winding stem straight toward the center of the main plate.

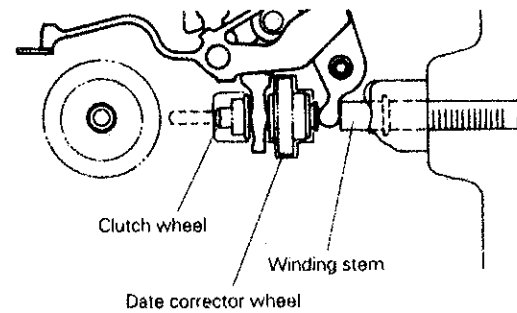

### III. VALUE CHECKING

• Coil block resistance

1.8KΩ ~ 2.2KΩ

• Current consumption

For the whole movement : Less than 0.8μA (with voltage supplied from a battery)  
For the circuit block alone : Less than 0.4μA (with voltage supplied from a battery)

<Measuring the current consumption for the whole movement>

- 1) Remove the solar cell unit.
- 2) Remove the rechargeable battery unit and tighten the battery lead terminal screw.
- 3) Connect the tester as shown in the illustration.
- 4) Start the measurement 30 seconds to 2 minutes after connecting the tester, checking that a stable measurement is obtained.

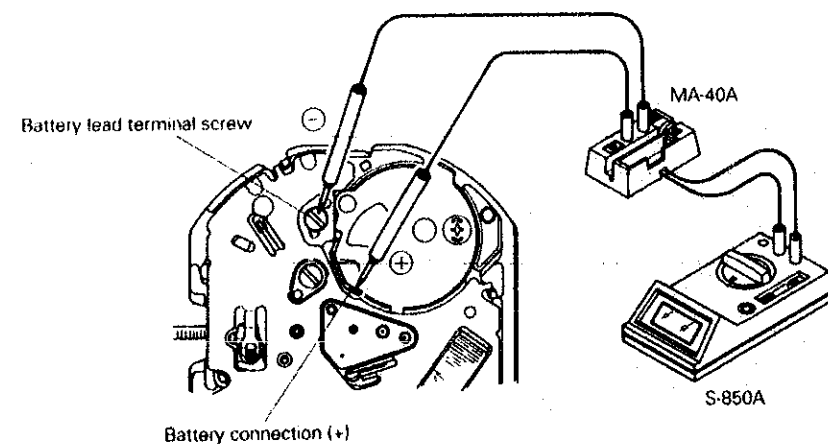

<Measuring the current consumption for the circuit block alone>

- Connect the tester to the input terminals (+) and (-) of the circuit block, and wait for 30 seconds to 2 minutes before starting the measurement, checking that a stable measurement is obtained.

**Remarks:** When the current consumption exceeds the standard value for the whole movement but is within the standard value range for the circuit block alone, the watch is generating a driving pulse to compensate for the heavy load that may be applied to the gear train, etc. In this case, overhaul and clean the movement parts and then measure current consumption for the whole movement again.

• Output voltage for the solar cell unit

Output voltage when the watch is placed at a distance of 5cm under a fluorescent light of 15 to 20 watts: More than 2.3V.

- Use either of the following two methods to measure the output voltage for the solar cell unit.
  1. Measurement of the output voltage for the watch
  2. Measurement of the output voltage for the solar cell unit alone

**Remarks:** If the output voltage for the watch is less than the specified value, measure the output voltage for the solar cell unit alone. If the output voltage for the solar cell unit alone exceeds the specified value, check the solar cell lead terminal for conductivity, etc.

<Measuring the output voltage for the watch>

- 1) Set the dial to the solar cell unit.
- 2) Make sure that the rechargeable battery unit is not installed into the watch.
- 3) Pull out the crown to the second click and reset the circuit.
- 4) Connect the tester as shown in the illustration.

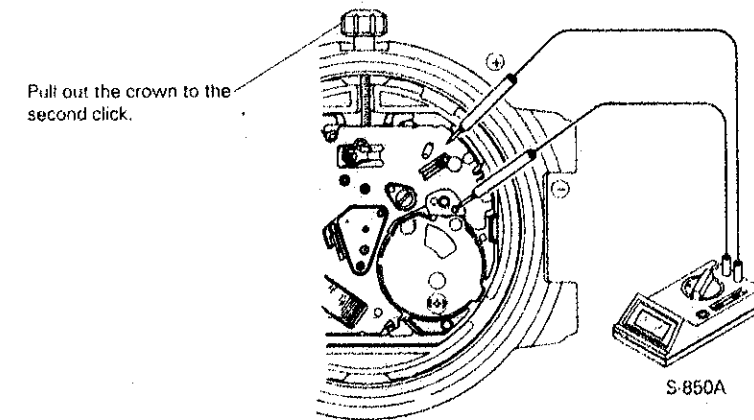

- 5) Place the watch at a distance of 5cm under a fluorescent light of 15 to 20 watts, exposing the dial side to the light, and then measure the output voltage.

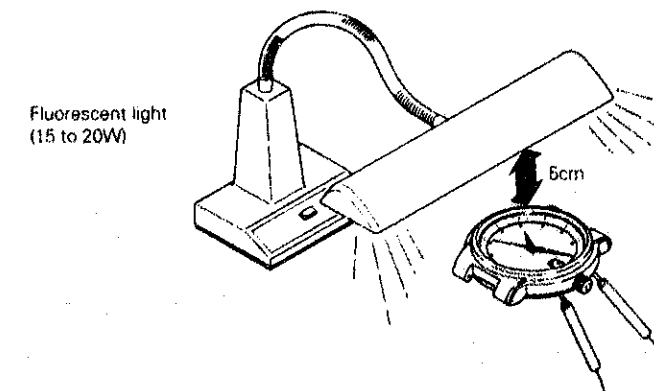

# TECHNICAL GUIDE

Cal. V145A

## <Measuring the output voltage for the solar cell unit alone>

- 1) Set the dial to the solar cell unit.
- 2) Connect the tester as shown in the illustration.

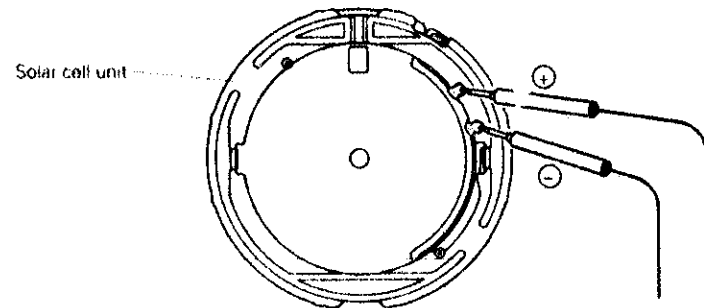

- 3) Place the solar cell unit at a distance of 5 cm under a fluorescent light of 15 to 20 watts, exposing the dial side to the light, and then measure the output voltage.

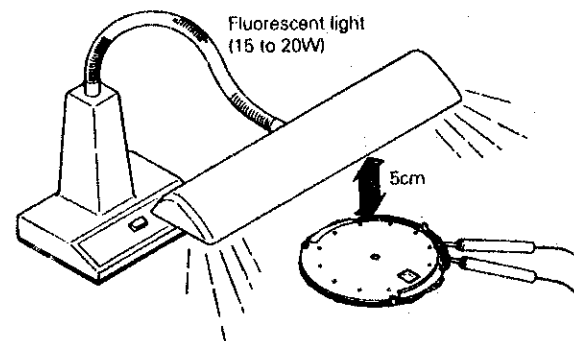

## • Checking the quick-start function

The quick-start function can be checked only when the rechargeable battery voltage is less than 0.9V. Before checking the function, therefore, be sure to measure the voltage. (Refer to step 1 in "• Checking the recharging function".)

## <Checking procedure>

- After checking that the watch stops operating, place the watch at a distance of 50cm under a fluorescent light of 15 to 20 watts, exposing the dial side to the light. Then, check if the second hand starts moving at 2-second intervals within 10 seconds.

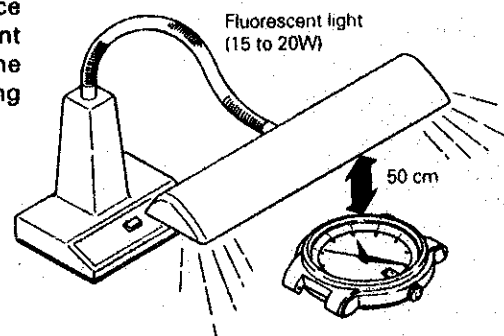

# TECHNICAL GUIDE

Cal. V145A

## • Checking the recharging function

A conventional method of checking the recharging function is to check the difference of the rechargeable battery voltage between before and after a recharge.

## <Checking procedure>

- 1) Apply the probes of the tester as shown in the illustration to measure the voltage of the rechargeable battery before recharge.

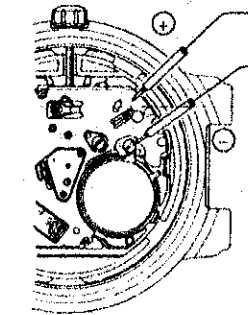

- 2) Place the watch at a distance of 5cm under a fluorescent light of 15 to 20 watts, and charge it for 30 minutes.

## Remarks:

- Be sure to use a fluorescent light to charge the watch, as light sources generating heat may cause damage to the watch. To charge the watch efficiently, place it under the center of the fluorescent tube.
- While charging the watch, make sure that the watch temperature does not exceed 50°C.

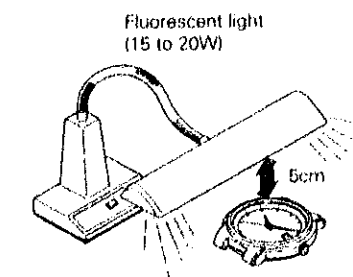

- 3) After recharging for 30 minutes, apply the probes of the tester in the same manner as in step 1) above, and measure the rechargeable battery voltage while keeping the watch exposed to the light.

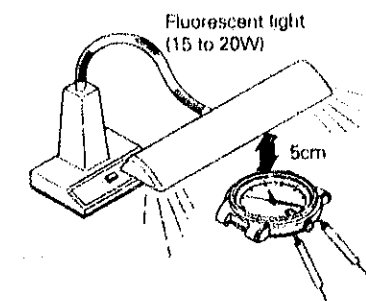

- 4) Refer to the table below to determine whether the recharging function is normal or not.

## [Guideline for the quality of the recharging function]

Voltage before recharge	Criteria for recharging quality
0.5 ~ 1.00V	The battery is normal if the rechargeable battery voltage obtained after recharge is more than 1.1V.
1.01 ~ 1.50V	The battery is normal if the rechargeable battery voltage has increased more than 0.03V after recharge.

\* The above criteria are applicable only when the rechargeable battery voltage before recharge is within the range between 0.5V and 1.5V.

• **Remarks on measuring the time accuracy**

- Before measuring the time accuracy, be sure to install the solar cell unit.
- If it is necessary to measure the accuracy while the solar cell unit is not installed and a stable measurement cannot be obtained, place the watch on the microphone of the quartz tester and leave it untouched for more than 2 minutes. Then, measure the accuracy again.

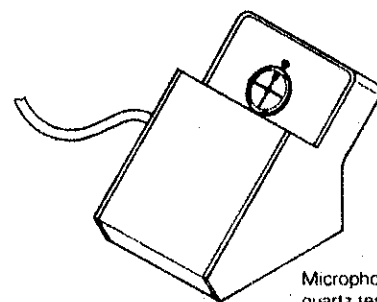

Microphone of the quartz tester

• **Guideline of charging time**

Illumination (lux)	Light source	Environment	Time required for full charge	Time required for 1-second intervals *	Time required to maintain one-day usage
500	60-watt incandescent light	Distance of 60 cm	250 hours	15 hours	60 minutes
700	Fluorescent light	Office, overhead	175 hours	11 hours	50 minutes
1,000	30-watt fluorescent light	Distance of 70 cm	120 hours	6 hours	30 minutes
3,000	30-watt fluorescent light	Distance of 20 cm	40 hours	2 hours	10 minutes
5,000	30-watt fluorescent light	Distance of 12 cm	22 hours	80 minutes	6 minutes
10,000	30-watt fluorescent light	Distance of 3 cm	10 hours	30 minutes	3 minutes
10,000	Sun	Cloudy weather	10 hours	30 minutes	3 minutes
100,000	Sun	Fair weather	3 hours	8 minutes	1 minute

• The above table provides only a general guideline, and the actual charging time may differ from model to model.

\* The values in this column represent the charging times required until the second hand moves constantly at 1-second intervals after the watch starts operating with the second hand moving at 2-second intervals. Even if the watch is not charged for the time specified in the column, the second hand may temporarily move at 1-second intervals. But, it will soon resume moving at 2-second intervals, and therefore, charge the watch for more than the specified period.

**[Caution for charging]**

- To prevent damage to the watch caused by heat from a light source, make sure that the watch temperature does not exceed 50°C while charging the watch.